

Quotation

	Description
0100-011 MODEL	Metro Star
8012-019 CUSTOMERS / OEMS	Toyne (TOY1000)[1002914]
8011-019 MODEL YEAR	Model Year - 2019
8001-001 COUNTRY OF SERVICE	Country of Service United States Of America
8017-001 CAB AND CHASSIS LABELING LANGUAGE	Cab and Chassis Labeling Language English
8006-009 APPARATUS TYPE	Apparatus Type Pumper
8008-001 VEHICLE TYPE	Vehicle Type Straight Truck
8008A-000 VEHICLE ANGLE OF APPROACH PACKAGE	Vehicle Angle of Approach NFPA Minimum 8.00 Degrees
0104-001 AXLE CONFIGURATION	Axle Configuration 4x2 (Rear Axle Drive Only)
0101-003 GROSS AXLE WEIGHT RATINGS FRONT	GAWR Front 20000#
0102-004 GROSS AXLE WEIGHT RATINGS REAR	GAWR Rear 27000#
8010-201 PUMP PROVISION	Pump Provision Driveline Midship, Pump Mode Prog w/Auto Park Brake "N"
8009-013 WATER & FOAM TANK CAPACITY	Water & Foam Tank Capacity 750 to 1250 Gallons
1000-004 CAB STYLE	Cab Style MFD 10" Raised Roof
8101-105 OCCUPANT PROTECTION	Occupant Protection Advanced Protection System
1501-002 CAB FRONT FASCIA	Cab Frt Fascia Classic
1518-025 FRONT GRILLE	Cab Frt Grille Hinged Classic Styled
1551-002 CAB UNDERCOAT	Cab Undercoat
1552-002 CAB SIDE DRIP RAIL	Cab Side Drip Rail
1521-002 CAB PAINT EXTERIOR	Cab Paint Exterior Two Tone
1533-001 CAB PAINT MANUFACTURER	Cab Paint Manufacturer PPG
1522-086 CAB PAINT PRIMARY/LOWER COLOR	Cab Paint Primary/Lower Color PPG Red FBCH 71663
1523-244 CAB PAINT SECONDARY/UPPER COLOR	Cab Paint Sec/Upper Color PPG White FBCH 2185
1524-002 CAB PAINT EXTERIOR BREAKLINE	Cab Paint Exterior Breakline Classic
1515-005 CAB PAINT PINSTRIPE	Cab Paint Pinstripe 1/2" Black Temporary
8013-042 CAB PAINT WARRANTY	Cab Paint Warranty 2019 (10) Year/100,000 Miles
1334-039 CAB PAINT INTERIOR	Cab Paint Int Multi-tone Onyx Blk
1005-001 CAB ENTRY DOORS	Cab Entry Doors (4)
1101-101 CAB ENTRY DOOR TYPE	Cab Entry Door Type Full Length w/Pollak Switches
1322-002 CAB INSULATION	Cab Insulation
8004-026 CAB STRUCTURAL WARRANTY	Cab Structural Warranty 2019 (10) Year/100,000 Miles
9001-006 CAB TEST INFORMATION	Cab Test Information Crash Test ECE-R29/SAE J2420/SAE J2422
5000-018 ELECTRICAL SYSTEM	Elec System 12V DC Multiplex
5005-214 MULTIPLEX DISPLAY	MUX Display Weldon VFD Display
5004-002 LOAD MANAGEMENT SYSTEM	Load Management System Multiplex
5622-003 DATA RECORDING SYSTEM	Data Recording Sys Vehicle Data Weldon MUX
5031-007 ACCESSORY POWER	Accessory Pwr & Gnd Stud 40A Batt Dir & 15A Ign Sw & 200A Mstr Sw w/Fus OEM Conn
5030-066 AUXILIARY ACCESSORY POWER	Aux Acc Pwr & Gnd Stud Bhd Sw Pnl 60A Mstr Sw

5032-053	ADDITIONAL ACCESSORY POWER	Addl Acc Pwr 10 Fuse Pnl Bhd Off Seat w/20A Fuse Ign Sw
5011-001	EXTERIOR ELECTRICAL TERMINAL COATING	Exterior Electrical Terminal Coating Spray On Plasti Dip
1701-158	ENGINE	Engine Diesel 450HP Cummins L9 - EPA 2017
1329-001	CAB ENGINE TUNNEL	Cab Engine Tunnel Small/Medium
1731-002	DIESEL PARTICULATE FILTER CONTROLS	DPF Ctrl Regeneration Sw & Inhibit Sw
1718-002	ENGINE PROGRAMMING HIGH IDLE SPEED	Engine Programming High Idle Speed 1250 RPM
1719-004	ENGINE HIGH IDLE CONTROL	Engine High Idle Ctrl Manual and Automatic
1710-001	ENGINE PROGRAMMING ROAD SPEED GOVERNOR	Engine Programming Road Speed Governor Enabled
1713-010	AUXILIARY ENGINE BRAKE	Aux Engine Brake Compression Brake w/VG Turbo
1708-004	AUXILIARY ENGINE BRAKE CONTROL	Aux Engine Brake Ctrl On/Off & Low/Med/High Sw Pnl
1720-003	ELECTRONIC ENGINE OIL LEVEL INDICATOR	Elec Engine Oil Level Indicator
1715-001	FLUID FILLS	Fluid Fills Fwd For Med Displacement Cap
1735-001	ENGINE DRAIN PLUG	Engine Drain Plug
8002-001	ENGINE WARRANTY	Engine Warranty Cummins (5) Year/100,000 Miles
1707-110	REMOTE THROTTLE HARNESS	Rmt Throttle Harness PSG FRC Pump Boss Side Mnt Shift Interlock
1721-001	ENGINE PROGRAMMING REMOTE THROTTLE	Engine Program Rmt Throttle Off
1727-001	ENGINE PROGRAMMING IDLE SPEED	Engine Programming Idle Speed 700 RPM
2704-002	ENGINE FAN DRIVE	Engine Fan Drive Clutch
2701-019	ENGINE COOLING SYSTEM	Engine Cooling Sys Serial Flow Medium/Package Drop-Out Prov/Rwd Sight Glass
2711-005	ENGINE COOLING SYSTEM PROTECTION	Engine Cooling System Protection Light Duty Skid Plate Paint Frame Color
2708-001	ENGINE COOLANT	Engine Coolant Extended Life
2706-003	ELECTRONIC COOLANT LEVEL INDICATOR	Elec Low Coolant Level Indicator
2705-002	ENGINE PUMP HEAT EXCHANGER	Engine Pump Heat Exchanger
2709-004	COOLANT HOSES	Coolant Hoses Silicone Heater & Radiator w/Cab Int Rubber Hoses
2801-009	ENGINE AIR INTAKE	Engine Air Intake Filtration and Restriction w/SS Housing & Replaceable Element
2802-003	AIR INTAKE PROTECTION	Air Intake Protection Light Duty Skid Plate Painted Frame Color
2901-068	ENGINE EXHAUST SYSTEM	Eng Exhaust Sys Under Frm RH Single Module Aftertreatment Inboard
2907-003	DIESEL EXHAUST FLUID TANK	Diesel Exhaust Fluid Tank LH 6 Gal Fill Thru Rr Step
2902-010	ENGINE EXHAUST ACCESSORIES	Engine Exh Acc Exh Temp Mitigation
2906-002	ENGINE EXHAUST WRAP	Engine Exhaust Wrap
1801-015	TRANSMISSION	Transmission Allison 3000 EVS
1806-004	TRANSMISSION MODE PROGRAMMING	Transmission Mode Programming 6th Startup/6th Mode
1811-004	TRANSMISSION FEATURE PROGRAMMING	Transmission Feature Programming Allison Gen V-E I/O Package 198/Pumper
1815-002	ELECTRONIC TRANSMISSION OIL LEVEL INDICATOR	Elec Transmission Oil Level Indicator
1807-005	TRANSMISSION SHIFT SELECTOR	Transmission GEN V-E Shift Sel Key Pad/Push Button
1814-002	TRANSMISSION PRE-SELECT WITH	2nd Gear Pre-Select

AUXILIARY BRAKE

1808-007	TRANSMISSION COOLING SYSTEM	Transmission Cooling System
1817-001	TRANSMISSION DRAIN PLUG	Transmission Drain Plug
8005-001	TRANSMISSION WARRANTY	Transmission Warranty Allison (5) Year
2005-009	PTO LOCATION	PTO Location 8:00/4:00
3001-001	DRIVELINE	Driveline Spicer 1710
3005-061	MIDSHIP PUMP / GEARBOX	Midship Pump Jackshaft w/Toyne Module Holes
3008-054	MIDSHIP PUMP / GEARBOX MODEL	Midship Pump/Gearbox Model Hale QMAX
3048-004	MIDSHIP PUMP GEARBOX DROP	Midship Pump Gearbox Drop Hale "L"
3009-020	MIDSHIP PUMP RATIO	Midship Pump Ratio 2.28:1 (23)
3010-0800	MIDSHIP PUMP LOCATION C/L SUCTION TO C/L REAR AXLE	Midship Pump Location C/L Suction to C/L Rear Axle 80.0"
3109-060	FUEL FILTER/WATER SEPARATOR	Fuel Filter/Wtr Separator Fleetguard FS1098 w/Lt & Alarm
3111-001	FUEL LINES	Fuel Lines Nylon
3103-008	ELECTRIC FUEL PRIMER	Electric Fuel Primer Engine Sply Electric Lift Pump
3101-101	FUEL TANK	Fuel Tank 50 Gallon
3130-001	FUEL TANK MATERIAL AND FINISH	Fuel Tank Material Steel & Finish Painted Frame Color
3131-001	FUEL TANK STRAP MATERIAL AND FINISH	Fuel Tank Strap Material Steel & Finish Painted Frame Color
3102-007	FUEL TANK FILL PORT	Fuel Tank Fill Port LH Rwd/RH Mid
3115-002	FUEL TANK DRAIN PLUG	Fuel Tank Drain Plug Magnetic
2401-003	FRONT AXLE	Frt Axle Meritor MFS 20000# Beam
8059-015	FRONT AXLE WARRANTY	Front Axle Warranty Meritor 2019
2405-001	FRONT WHEEL BEARING LUBRICATION	Frt Wheel Bearing Lube Oil
2502-002	FRONT SHOCK ABSORBERS	Frt Shock Absorbers Bilstein
2501-016	FRONT SUSPENSION	Frt Suspension 10 Leaf 20000-21500#
2601-006	STEERING COLUMN/WHEEL	Steering Column/Wheel Tilt/Telescopic 18" 4 Spoke
2609-002	ELECTRONIC POWER STEERING FLUID LEVEL INDICATOR	Elec Power Steering Fluid Level Indicator
2603-011	POWER STEERING PUMP	Power Steering Pump TRW w/Passive Cooler
2606-009	FRONT AXLE CRAMP ANGLE	Front Axle Cramp Angle 48L/44R Degrees
2610-003	POWER STEERING GEAR	Power Steering Gear TRW TAS 65 w/Assist
2608-001	CHASSIS ALIGNMENT	Chassis Alignment
3401-003	REAR AXLE	Rear Axle 27000# Meritor RS-25-160
3403-001	REAR AXLE DIFFERENTIAL LUBRICATION	Rear Axle Differential Lubrication Oil
8061-012	REAR AXLE WARRANTY	Rear Axle Warranty Meritor 2019
3411-001	REAR WHEEL BEARING LUBRICATION	Rear Wheel Bearing Lubrication Oil
3408-008	VEHICLE TOP SPEED	Vehicle Top Speed 68 MPH
3501-032	REAR SUSPENSION	Rear Susp Reyco 79KB Spring 21000-31500# Conventional
3601-038	FRONT TIRE	Frt Tire 315/80R 22.5 Goodyear G289 WHA
3602-043	REAR TIRE	Rear Tire 12R 22.5 Goodyear G622 RSD
3413-538	REAR AXLE RATIO	Rear Axle Ratio 5.38
3614-030	TIRE PRESSURE INDICATOR	Tire Pressure Ind Frt & Rr LED
3701-037	FRONT WHEEL	Frt Wheel Alcoa Dura-Bright LvL One 22.5 x 9.00 Alum

3703-028	REAR WHEEL	Rr Whl Alcoa Dura-Bright LvL One 22.5 x 8.25 Alum
3702-002	WHEEL TRIM	Wheel Trim Hub & Nut Covers SS Shiploose
3725-002	WHEEL GUARDS	Wheel Guards Between Dual Rear Wheels
3205-002	BRAKE SYSTEM	Brake System ABS/ATC Sgl Axle
3206-001	FRONT BRAKES	Frt Brakes S-Cam Drum 16.5" x 6"
3207-005	REAR BRAKES	Rr Brakes S-Cam Drum 16.5" x 7" Cast Iron Shoe
3208-001	PARK BRAKE	Prk Brake Rr Wheels Only
3204-029	PARK BRAKE CONTROL	Prk Brake Ctrl LH Tunnel Mnt, Integrated w/Shift Pod Console
3213-001	FRONT BRAKE SLACK ADJUSTERS	Frt Brake Slack Adjusters Meritor
3214-001	REAR BRAKE SLACK ADJUSTERS	Rr Brake Slack Adjusters Meritor
3202-005	AIR DRYER	Air Dryer Wabco System Saver 1200 Bhd LH Batt Box
3215-001	FRONT BRAKE CHAMBERS	Frt Brake Chambers MGM Type 30
3210-015	REAR BRAKE CHAMBERS	Rr Brake Chambers TSE 30/36 Long Stroke
3320-001	AIR COMPRESSOR	Air Compressor Wabco SS318 18.7 CFM
3339-004	AIR GOVERNOR	Air Governor Mnt on Air Dryer Bracket
3303-006	MOISTURE EJECTORS	Moisture Ejectors Manual/Auto Wet Tank
3307-001	AIR SUPPLY LINES	Air Sply Lines Nylon
3334-002	AIR TANK SPACERS	Air Tank Spacers Inboard 1.5"
2103-1720	WHEELBASE	Wheelbase 172.0"
2106-0370	REAR OVERHANG	Rear Overhang 37.0"
2101-002	FRAME	Frame Double Channel 35.00" Width
8007-024	FRAME WARRANTY	Frame Warranty Lifetime 2019
2111-096	MISC FRAME OPTIONS	Misc Frame Options Toyne Pumper Body Mnt Hole Pattern #1
2117-028	FRAME CLEAR AREA	Frame Clear Area Inside LH Rail 34" To 46" Fwd From C/L of R/A
2110-201	FRAME PAINT	Frame Paint Hot Dipped Galvanized - Frame Only Addl Comp Blk Powder Coat
2201-001	FRONT BUMPER	Frt Bumper Stainless Steel Flat
2202-005	FRONT BUMPER EXTENSION LENGTH	Frt Bumper Extension Length 21"
2215-002	FRONT BUMPER SUCTION PROVISION	Frt Bumper Suction Provision 5.0" RH Vertical Outboard
2208-006	FRONT BUMPER APRON	Frt Bumper Apron For 21" Extension
2237-004	FRONT BUMPER DISCHARGE	Front Bumper Discharge 2.0" LH Frame Mnt Plumbing
2211-003	FRONT BUMPER COMPARTMENT CENTER	Frt Bumper Cmpt Ctr w/Cover
2210-002	FRONT BUMPER COMPARTMENT COVER HARDWARE	Frt Bumper Cmpt Cover Hardware Gas Cylinder/D-ring
5501-020	AIR HORN	Air Horn (2) 21" Round Hadley E-Tone
2216-020	AIR HORN LOCATION	Air Horn Location (2) Frt Bmpr Face Ctr R/L OB
2232-002	AIR HORN RESERVOIR	Air Horn Reservoir (1) 1200 Cu In
5504-029	ELECTRONIC SIREN SPEAKER	Elect Siren Speaker 100W Cast Products SA4301
2217-005	ELECTRONIC SIREN SPEAKER LOCATION	Elec Siren Speaker Location Frt Bmpr Face RH OB
2203-001	FRONT BUMPER TOW HOOKS	Frt Bumper Tow Hooks Chrome Below Fwd
2301-001	CAB TILT SYSTEM	Cab Tilt System
2303-002	CAB TILT LIMIT SWITCH	Cab Tilt Limit Sw
2305-001	CAB TILT CONTROL RECEPTACLE	Cab Tilt Ctrl Receptacle Temp

2306-002	CAB TILT LOCK DOWN INDICATOR	Cab Tilt Lock Down Indicator
1401-009	CAB WINDSHIELD	Cab Windshield
1402-005	GLASS FRONT DOOR	Glass Frt Dr Roll Down/XDuty Regulator
1407-001	GLASS TINT FRONT DOOR	Glass Tint Frt Dr Automotive Green
1419-012	GLASS REAR DOOR RIGHT HAND	Glass Rr Dr RH Roll Down/XDuty Regulator
1430-001	GLASS TINT REAR DOOR RIGHT HAND	Glass Tint Rr Door RH Automotive Green
1412-013	GLASS REAR DOOR LEFT HAND	Glass Rr Dr LH Roll Down/XDuty Regulator
1431-001	GLASS TINT REAR DOOR LEFT HAND	Glass Tint Rr Door LH Automotive Green
1410-003	GLASS SIDE MID RIGHT HAND	Glass Side Mid RH Fxd 16"W x 26"H
1432-001	GLASS TINT SIDE MID RIGHT HAND	Glass Tint Side Mid RH Automotive Green
1409-003	GLASS SIDE MID LEFT HAND	Glass Side Mid LH Fxd 16"W x 26"H
1433-001	GLASS TINT SIDE MID LEFT HAND	Glass Tint Side Mid LH Automotive Green
1614-202	CLIMATE CONTROL	Climate Ctrl Htr Defroster A/C SGM Ovrhd Alum
1632-002	CLIMATE CONTROL DRAIN	Climate Control Drain Gravity
1617-104	CLIMATE CONTROL ACTIVATION	Climate Ctrl Actv Rotary Dash Mnt Ctr Lwr LH
1620-019	HVAC OVERHEAD COVER PAINT	HVAC Overhead Cover Paint Multi-tone Onyx Black
1603-003	A/C CONDENSER LOCATION	A/C Condenser Location Roof Mnt Fwd Ctr
1601-013	A/C COMPRESSOR	A/C Compressor TM-31/QP-31
1530-001	UNDER CAB INSULATION	Under Cab Insulation Engine Tunnel
1327-001	INTERIOR TRIM FLOOR	Interior Trim Floor
1302-001	INTERIOR TRIM	Interior Trim Vinyl
1368-003	REAR WALL INTERIOR TRIM	Rear Wall Interior Trim Painted Aluminum
1306-006	HEADER TRIM	Header Trim XDuty
1305-014	TRIM CENTER DASH	Trim Center Dash XDuty
1339-102	TRIM LEFT HAND DASH	Trim LH Dash XDuty
1321-004	TRIM RIGHT HAND DASH	Trim RH Dash XDuty Glove Cmpt/MDT Prov
1307-002	ENGINE TUNNEL TRIM	Eng Tnl Trim Flr Mat
5040-101	POWER POINT DASH MOUNT	Pwr Pnt Dash Mnt Batt Dir (1) Sw Pnl/(2) Dual USB Blue Sea 2.1A Sw Pnl
1303-017	STEP TRIM	Step Trim Grip Strut Lwr Flex-Tred Mid
1379-003	UNDER CAB ACCESS DOOR	Under Cab Access Door Rear Step LH Painted
1102-013	INTERIOR DOOR TRIM	Interior Door Trim Painted
1323-001	DOOR TRIM CUSTOMER NAMEPLATE	Door Trim Customer Nameplate
1105-001	CAB DOOR TRIM REFLECTIVE	Cab Dr Trim Reflective Vert Stripe/6" Chevron w/Logo
1308-001	INTERIOR GRAB HANDLE "A" PILLAR	Interior Grab Handle 'A' Pillar 11" Molded
1332-008	INTERIOR GRAB HANDLE FRONT DOOR	Interior Grab Handle Frt Door Horiz 9"
1345-002	INTERIOR GRAB HANDLE REAR DOOR	Int Grab Handle Rr Dr Alum Window Span 30" Black Powder Coat
1301-001	INTERIOR SOFT TRIM COLOR	Interior Soft Trim Color Black
1337-004	INTERIOR TRIM SUNVISOR	Interior Trim Sunvisor Vinyl Black
1304-002	INTERIOR FLOOR MAT COLOR	Interior Floor Mat Color Black
1335-018	CAB PAINT INTERIOR DOOR TRIM	Cab Paint Int Dr Trim Multi-tone Onyx Black
1371-021	HEADER TRIM INTERIOR PAINT	Header Trim Interior Paint Multi-tone Onyx Black
1370-023	TRIM CENTER DASH INTERIOR PAINT	Trim Center Dash Interior Paint Multi-tone Onyx Black
1378-022	TRIM LEFT HAND DASH INTERIOR PAINT	Trim LH Dash Interior Paint Multi-tone Onyx Black

1373-022	TRIM RIGHT HAND DASH INTERIOR PAINT	Trim RH Dash Interior Paint Multi-tone Onyx Black
1369-018	REAR WALL INTERIOR PAINT	Rear Wall Interior Paint Multi-tone Onyx Black
1344-002	DASH PANEL GROUP	Dash Pnl Group 3-Pnl
1312-005	SWITCHES CENTER PANEL	Switches Ctr Pnl 12 Upr
1313-028	SWITCHES LEFT PANEL	Switches Left Pnl 10 (6+4) w/Headlight/Dimmer/Wiper
1314-001	SWITCHES RIGHT PANEL	Switches Right Pnl 0
1225-018	SEAT BELT WARNING	Seat Belt Warn Indv Seat Loc & LED Display w/VDR Weldon
1237-005	SEAT MATERIAL	Seat Material Durawear Plus
1243-001	SEAT COLOR	Seat Color Gray/Red Seat Belts
1249-126	SEAT BACK LOGO	Seat Back Logo Toyne
1201-033	SEAT DRIVER	Seat Driver Bostrom Firefighter 8-Way Elect 500 Series ABTS
1213-025	SEAT BACK DRIVER	Seat Back Driver Non-SCBA ABTS
1219-001	SEAT MOUNTING DRIVER	Seat Mounting Driver
8102-103	OCCUPANT PROTECTION DRIVER	Occupant Protection Driver Advanced Protection System
1202-037	SEAT OFFICER	Seat Officer Bostrom Firefighter Fixed 500 Series ABTS
1214-030	SEAT BACK OFFICER	Seat Back Officer SCBA Bostrom SecureAll w/Quick-Adjust
1220-002	SEAT MOUNTING OFFICER	Seat Mounting Officer
8103-103	OCCUPANT PROTECTION OFFICER	Occupant Protection Officer Advanced Protection System
1297-002	POWER SEAT WIRING	Power Seats Wiring Battery Direct
1273-001	SEAT BELT ORIENTATION CREW	Seat Belt Orientation Crew Outboard Shoulder To Inboard Hip
1263-001	SEAT REAR FACING OUTER LOCATION	Seat RFO Location (2) R/L
1203-020	SEAT CREW REAR FACING OUTER	Seat Crew RFO Bostrom Firefighter Fixed 500 Series
1215-027	SEAT BACK REAR FACING OUTER	Seat Back RFO SCBA Bostrom SecureAll w/Quick-Adjust
1221-009	SEAT MOUNTING REAR FACING OUTER	Seat Mounting RFO Rwd 2"
8104-103	OCCUPANT PROTECTION RFO	Occupant Protection RFO Advanced Protection System
1266-001	SEAT FORWARD FACING CENTER LOCATION	Seat FFC Location (2) Ctr
1206-031	SEAT CREW FORWARD FACING CENTER	Seat Crew FFC Bostrom Firefighter Fold & Hold Flip-Up 500 Series
1218-031	SEAT BACK FORWARD FACING CENTER	Seat Back FFC SCBA Bostrom SecureAll w/Quick-Adjust
8107-102	OCCUPANT PROTECTION FFC	Occupant Protection FFC Advanced Protection System
1269-101	SEAT FRAME FORWARD FACING	Seat Frm Fwd Fcg Dual
1281-101	SEAT FRAME FORWARD FACING STORAGE ACCESS	Seat Frm Fwd Fcg Strg Acc Dr (2) R/L Sd
1224-002	SEAT MOUNTING FORWARD FACING CENTER	Seat Mounting Forward Facing Center
1311-101	CAB FRONT UNDERSEAT STORAGE ACCESS DOOR	Cab Frt Undrst Strg Acc Dr
1355-023	SEAT COMPARTMENT DOOR FINISH	Seat Compartment Door Finish Multi-tone Onyx Black
1511-100	WINDSHIELD WIPER SYSTEM	Windshield Wiper System
1534-002	ELECTRONIC WINDSHIELD FLUID LEVEL INDICATOR	Electronic Windshield Fluid Level Indicator
1103-002	CAB DOOR HARDWARE	Cab Door Hardware Black
1111-001	DOOR LOCKS	Door Locks Manual
1503-002	GRAB HANDLES	Grab Handles SS 18"
1504-014	REARVIEW MIRRORS	Mirror Aerodynamic Retractable 613305 Rmt Htd

1529-004	REARVIEW MIRROR HEAT SWITCH	Rearview Mirror Heat Sw Mirror Ctrl Pnl
1513-002	CAB FENDER	Cab Fender Alum
1514-002	MUD FLAPS FRONT	Mud Flaps Frt
1526-027	CAB EXTERIOR FRONT & SIDE EMBLEMS	Cab Ext Frt & Side Emblems Spartan w/APS
5109-001	IGNITION	Ign Mstr Sw w/Keyless Start
5101-017	BATTERY	Batt (6) Group 31 Napa 7236
5106-003	BATTERY TRAY	Batt Tray (2) R/L Steel
5107-007	BATTERY BOX COVER	Batt Box Cover (2) Steel w/Black Handles
5102-001	BATTERY CABLE	Batt Cables
5108-010	BATTERY JUMPER STUD	Batt Jumper Stud Frt LH Lwr Step 8" Apart
5104-002	ALTERNATOR	Alternator Leece-Neville 320A
5105-001	STARTER MOTOR	Starter Motor Delco
5202-075	BATTERY CONDITIONER	Batt Cond Kussmaul Auto Charge 40 LPC LH RFO Seat Position
5203-002	BATTERY CONDITIONER DISPLAY	Batt Cond Display LH Mid Glass
3314-006	AUXILIARY AIR COMPRESSOR	Aux Air Cmp Kussmaul Auto Pump 120V Bhd Off Seat Mnt Horiz
5204-055	ELECTRICAL INLET	Elec Inlet 120V 20A Auto Eject
5209-002	ELECTRICAL INLET LOCATION	Elec Inlet Location LH Cab Side Mid
5210-005	ELECTRICAL INLET CONNECTION	Elec Inlet Conn to Batt Conditioner & Air Pump
5206-002	ELECTRICAL INLET COLOR	Elec Inlet Color Yellow
5301-102	HEADLIGHTS	Headlights 4 Headlamps LED
5303-004	FRONT TURN SIGNALS	Frt Turn Signals Whelen 600 LED
5337-001	HEADLIGHT LOCATION	Headlights Below Frt Warn Lts
5336-003	SIDE TURN/MARKER LIGHTS	Side Turn/Marker Lts LED
5302-003	MARKER & ICC LIGHTS	Marker & ICC Lts Face Mnt LED
5350-050	HEADLIGHT AND MARKER LIGHT ACTIVATION	Hdlt & Mrkr Lt Actv Rkr Sw/DRL
5308-004	GROUND LIGHTS	Ground Lts LED Resp Dr & Rkr Sw
5309-003	LOWER CAB STEP LIGHTS	Lwr Cab Step Lts LED
5382-002	INTERMEDIATE STEP LIGHTS	Intermediate Step Lts LED
5312-003	ENGINE COMPARTMENT LIGHT	Engine Cmpt Work Lt LED (1)
5403-062	LIGHTBAR PROVISION	Lightbar Prov Wire & Lwr Mnt Spartan Supply
5450-234	CAB FRONT LIGHTBAR	Cab Frt Ltbar Whelen Freedom F4N72QLED 8R2C Layout 1
5426-002	LIGHTBAR SWITCH	Lightbar Sw Pnl
5317-144	FRONT SCENE LIGHTS	Frt Scene Lts FRC Spectra MAX-S 12V LED 28K Contour Mnt
5335-045	FRONT SCENE LIGHTS ACTIVATION	Frt Scene Lts Actv Rkr Sw Pnl
5329-003	FRONT SCENE LIGHT LOCATION	Frt Scene Lt Loc Ctr Brow Pos
5306-060	SIDE SCENE LIGHTS	Side Scene Lts Whelen M9 Series 12V LED
5318-004	SIDE SCENE LIGHT LOCATION	Side Scene Lt Loc Upper Mid Rwd 10" Roof Position
5316-003	SIDE SCENE ACTIVATION	Side Scene Actv Indv Sw
5305-166	INTERIOR OVERHEAD LIGHTS	Interior Overhead Lts Weldon LED w/Front Map Lts
5406-076	DO NOT MOVE APPARATUS LIGHT	Do Not Move App Lt Flashing Red Whelen Ion LED w/Alarm
5422-001	MASTER WARNING SWITCH	Mstr Warn Sw Pnl
5409-002	HEADLIGHT FLASHER	Headlight Flasher Alternating
5425-018	HEADLIGHT FLASHER SWITCH	Headlight Flasher Sw Pnl

5401-032	INBOARD FRONT WARNING LIGHTS	Inboard Frt Warn Lts Whelen M6 LED Chrm Bezel
5413-003	INBOARD FRONT WARNING LIGHTS COLOR	Inboard Frt Warn Lts Color Red w/Clr Lens
5423-007	FRONT WARNING SWITCH	Frt Warn Sw Pnl
5404-027	INTERSECTION WARNING LIGHTS	Intersection Warn Lts Whelen M6 Super LED
5419-003	INTERSECTION WARNING LIGHTS COLOR	Int Warn Lts Color Red w/Clr Lens
5420-002	INTERSECTION WARNING LIGHTS LOCATION	Intersection Warn Lts Location Bumper Tail Rwd
5402-029	SIDE WARNING LIGHTS	Side Warn Lts Whelen M6 Super LED
5418-003	SIDE WARNING LIGHTS COLOR	Side Warn Lts Color Red w/Clr Lens
5412-002	SIDE WARNING LIGHTS LOCATION	Side Warn Lts Location Lwr Mid
5424-008	SIDE AND INTERSECTION WARNING SWITCH	Side & Intersection Warn Sw Pnl
5510-004	SIREN CONTROL HEAD	Siren Ctrl Head Whelen 295HFS2
5514-002	HORN BUTTON SELECTOR SWITCH	Horn Btn Sel Sw Elec Horn/Air Horn
5512-005	AIR HORN ACTIVATION	Air Horn Actv Strg Whl/RH Lanyard
5505-002	BACK-UP ALARM	Back-Up Alarm Ecco 575
5601-041	INSTRUMENTATION	Instrumentation Standard
5624-001	BACKLIGHTING COLOR	Backlighting Color Red
5701-056	RADIO	Radio Jensen WB/AM/FM/CD/iPod/Sat Ovrhd LH
5707-002	AM/FM ANTENNA	AM/FM Antenna LH Fwd Cab Roof
5706-002	CAMERA	Cam Rr Box w/Mon
5703-011	COMMUNICATION ANTENNA	Comm Ant Base LH Fwd Cab Rf Spartan Sply
5708-002	COMMUNICATION ANTENNA CABLE ROUTING	Comm Ant Cable Routing Under RH Frt Seat
5709-002	AUXILIARY COMMUNICATION ANTENNA	Aux Comm Ant Base RH Fwd Cab Roof Spartan Sply
5710-003	AUXILIARY COMMUNICATION ANTENNA CABLE ROUTING	Aux Comm Ant Cable Routing Under Rkr Sw Pnl
5702-023	TWO-WAY RADIOS	Two-Way Radio Exterior Conduit to Under RH Seat
5020-001	PANEL LAYOUT	Panel Layout
8814-002	CAB EXTERIOR PROTECTION	Cab Exterior Protection Front
8806-001	FIRE EXTINGUISHER	Fire Extinguisher Shiploose
8810-001	DOOR KEYS	Door Keys for Manual Locks (4)
8811-003	DIAGNOSTIC SOFTWARE OCCUPANT PROTECTION	Diagnostic Software Occupant Protection Advanced Protection System
8003-155	WARRANTY	Warranty Cab and Chassis 2019 (2) Year
8030-006	CHASSIS OPERATION MANUAL	Chassis Operation Manual Digital Copy (2)
8031-024	ENGINE & TRANSMISSION OPERATION MANUAL	Eng & Trans Operation Man Eng Hard Copy/Trans Digital/Eng Owner Digital
8805-007	CAB/CHASSIS AS BUILT WIRING DIAGRAMS	Cab/Chassis As Built Wiring Diagrams Digital Copy (2)
8039-001	SALES TERMS	Sales Terms
9005-002	DRIVELINE LAYOUT CONFIRMATION	Driveline Layout Confirmation Required

Panel Visual Layout

5020-001 Panel Layout

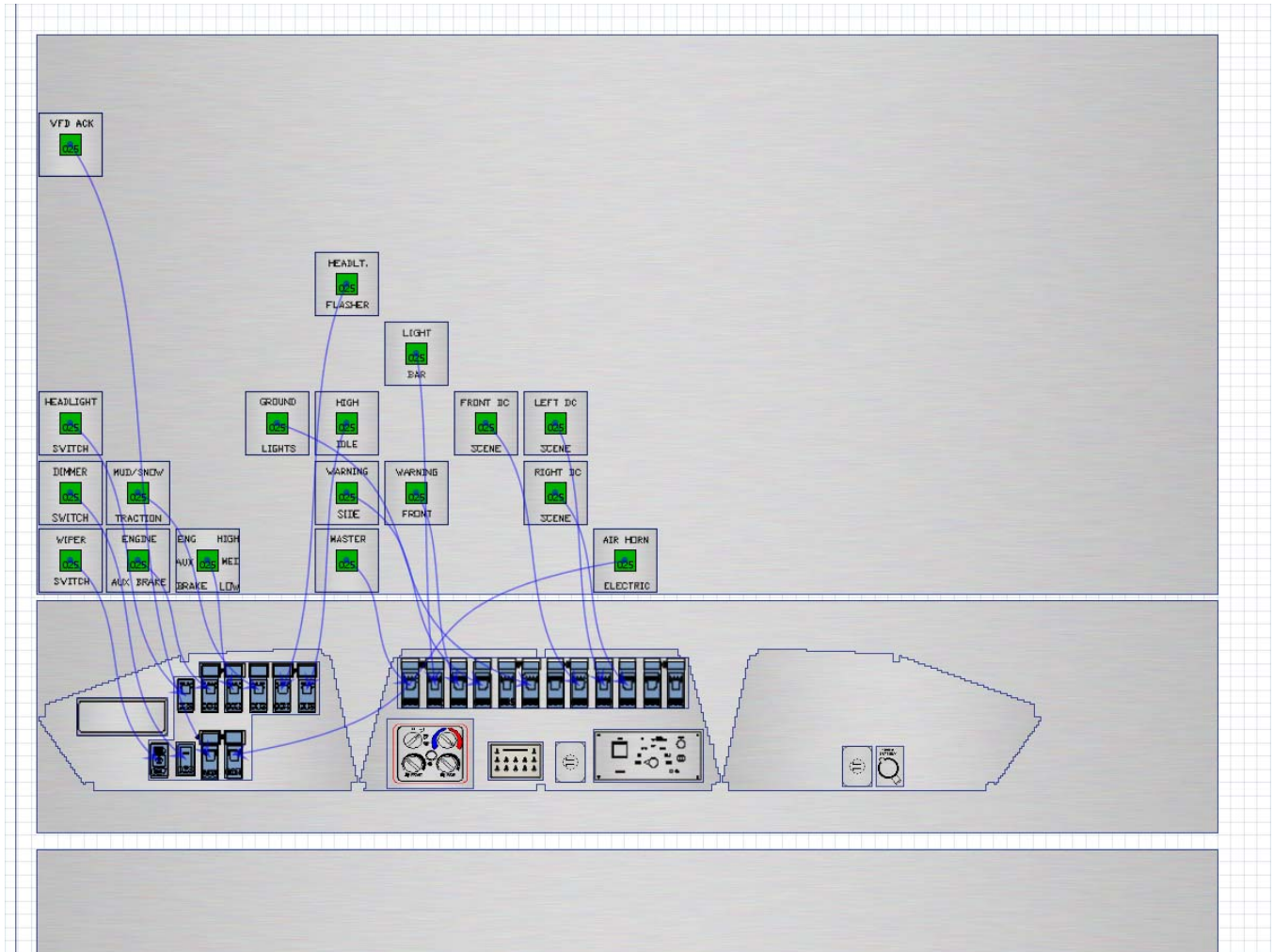

Weight Distribution

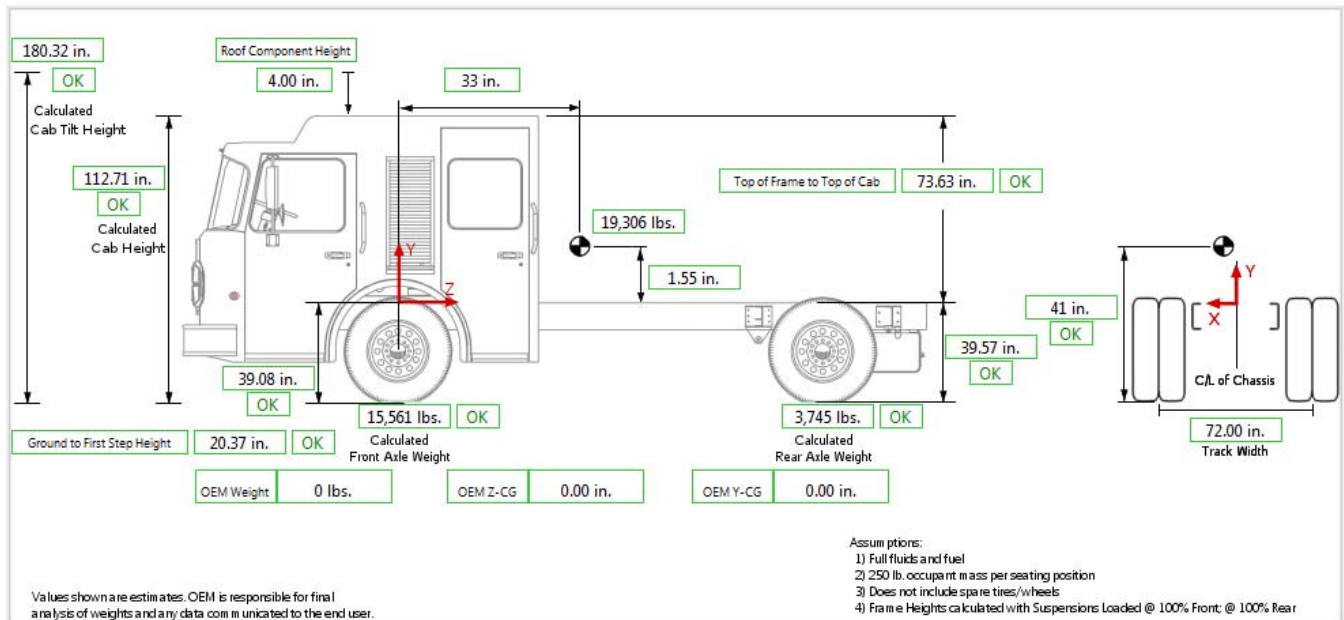

Calculated Apparatus Weight 19,306 lbs.
 Calculated Apparatus Z-CG 33 in.
 Calculated Apparatus Y-CG 1.55 in.

Note:

The Y-CG value above is calculated from the top of the frame.
 Apparatus refers to total combined value for cab and chassis and OEM inputs.

Seat Locations

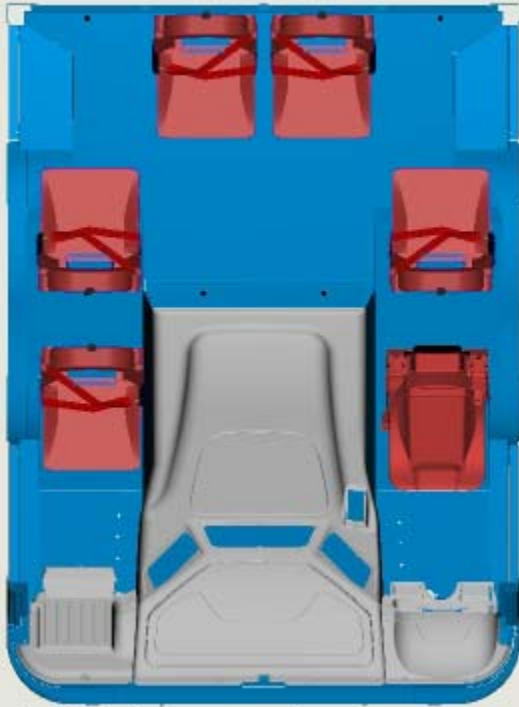

This drawing is for reference purposes only.

Frame Dimensions

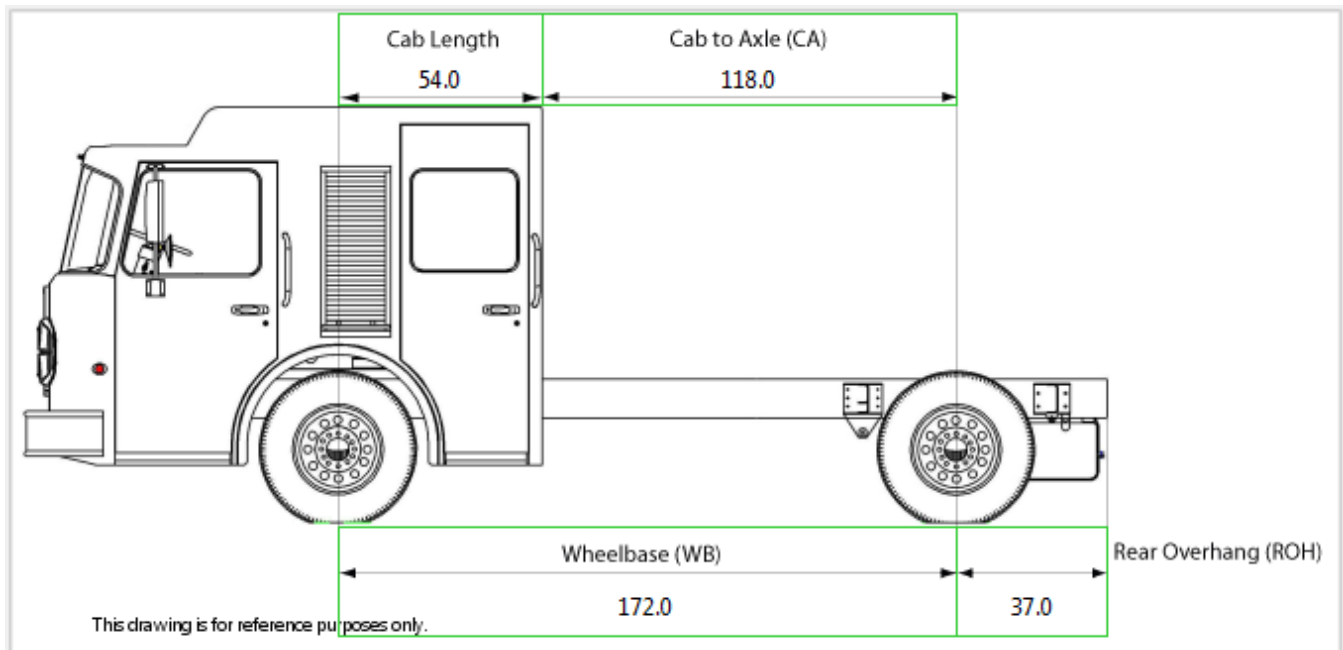

Toyne Inc.

00-05-7500

CORPORATE OWNERSHIP OF MANUFACTURER

The manufacturer of the apparatus must be fully owned and managed by a Parent Company, Corporation, or Individual(s) that is 100% held by United States of America based Company, Corporation, or United States citizen(s).

Proposals from any manufacturer that is fully or partially owned and/or operated by a foreign company, Corporation or Individual(s) under any type of ownership, partnership, or any similar type of agreement will be immediately rejected.

00-05-7520

CORPORATE CONTACT INFORMATION

The purchaser shall be provided with the following information to allow them to contact the President/CEO of the manufacturing company (not dealer) when deemed necessary:

- Name of Company President.
- Office address.
- Office telephone number.
- Email address.
- Home address.
- Home telephone number.
- 24/7 Cellular telephone number.

If the manufacturing company is a subsidiary of, division of, or owned by a different Company, the above information shall also be provided on the 'Parent' Company.

There will be no exception to this requirement.

00-05-7600

TOP OF THE LINE FIRE APPARATUS

If the manufacturer or bidder for the apparatus manufacturer represents two or more different lines of apparatus and/or operates two or more manufacturing plants, it should be clearly stated in the bid proposal.

In addition to this requirement, the bidder shall give a detailed explanation of why the particular line, brand, model or manufacturing facility will be used.

Manufacturer's or bidder's with multiple lines (two or more) or multiple manufacturing facilities (two or more) shall be required to submit bid proposals on only the top of the line brand/model or from the top of the line facility.

It is the intention of the purchaser to purchase a top of the line, first class, #1 quality fire apparatus. Any bidder that submits a bid on a "lower end" line, brand, model, or from a "lower end" manufacturing facility will be immediately rejected.

The purchaser is not interested in purchasing a manufacturer's or bidders "lower end" apparatus. Because of this, any bids submitted that do not comply with the above requirements will be

Toyne Inc.

immediately rejected.

00-10-1551

CERTIFICATION OF NFPA 1901-2016 COMPLIANCE

As per NFPA 1901, the Purchaser shall assume the responsibility of determining, prior to the purchase of the apparatus, who will be responsible for ensuring that all aspects of NFPA 1901 are met. The manufacturer shall be responsible for providing or performing only the items requested by the purchaser in the documents provided to the manufacturer by the purchaser.

Written certification shall be provided by the manufacturer stating that the delivered apparatus complies with the NFPA 1901 Standard. If the purchaser has elected to provide, perform, outsource and/or contract with a third party or waive any item required by NFPA 1901, the manufacturer shall provide, upon delivery, a "Statement of Exceptions" per Chapter 4 of NFPA 1901 4.21.

The "Statement of Exceptions" shall include:

- A separate specification of the section of the NFPA Standard for which the apparatus is lacking compliance.
- A description of the particular aspect of the apparatus that is not compliant therewith or required equipment that is missing.
- A description of the further changes or modifications to the delivered apparatus which must be completed to achieve full compliance.
- An identification of the entity that will be responsible for making the necessary post-delivery changes or modifications or for supplying and installing any missing required equipment to the apparatus to achieve full compliance to the standard.

Prior to, or at the time of, delivery of the apparatus, the Statement of Exceptions shall be signed by an authorized agent of the entity responsible for the final assembly of the apparatus and by an authorized agent of the purchasing entity, indicating a mutual understanding and agreement between the parties regarding the substance thereof.

The purchaser shall not place the apparatus into active emergency service until fully compliant with NFPA 1901.

00-10-4090

NFPA REQUIRED EQUIPMENT

The end user of this apparatus shall provide all other equipment and accessories that are required by NFPA 1901 but not specifically listed in these specifications.

00-10-4100

MAXIMUM TOP SPEED

The maximum top speed of this apparatus shall be determined using the following NFPA 1901 Chapter 4 criteria:

- Apparatus with 1250 gallon combined water tank capacity shall not exceed 60 MPH.
- Apparatus with GVWR of over 50,000 lbs. shall not exceed 60 MPH.
- Apparatus weighing over 26,000 lbs. shall not exceed 68 MPH.

Toyne Inc.

02-01-1021

HALE MODEL Q-MAX-XS 1500 GPM SINGLE STAGE PUMP

The fire pump shall be a Hale Fire Pump Company Q-MAX-XS that complies with all applicable requirements of the latest edition of the "Standard for Automotive Fire Apparatus" published by the National Fire Protection Association and printed in Pamphlet 1901.

02-31-0100

PUMP WARRANTY

The pump shall be covered by the Hale Pro-Tech 5-year pump warranty against workmanship and materials. Both parts and labor shall be covered for the first 2 years and years 3-5 shall have parts only coverage.

02-94-5100

UNDERWRITER'S LABORATORY CERTIFICATION

The completed apparatus shall be tested and approved by the independent testing company Underwriter's Laboratories, Inc. The manufacturer of the apparatus shall be responsible for all costs involved in this test. The certification of inspection and approval shall be presented to the Fire Chief of the Department upon delivery of the completed apparatus.

02-95-0800

PUMP PERFORMANCE - 1,500 U.S. GPM.

The pump shall be a single stage centrifugal with a class "A" rated capacity of 1,500 United States gallons per minute. The pump shall deliver the percentage of rated discharge pressures as indicated below:

- 100 percent of rated capacity at 150 pounds net pressure.
- 70 percent of rated capacity at 200 pounds net pressure.
- 50 percent of rated capacity at 250 pounds net pressure.
- 100 percent of rated capacity at 165 pounds net pressure.

02-96-0500

PUMP CONSTRUCTION

The entire pump shall be manufactured and tested at the pump manufacturer's factory.

The pump shall be driven by a drive line from the truck transmission. The pump shall be free from objectionable pulsation and vibration under all normal operating conditions. The engine shall provide sufficient horsepower and revolutions per minute to allow the pump to meet or exceed its rated performance.

The entire pump including both suction and discharge passages, shall be hydrostatically tested to a pressure of 500 psi. The pump shall be fully tested at the pump manufacturer's factory to the

Toyne Inc.

performance spots as outlined by NFPA 1901.

The pump body and related parts shall be of fine grain alloy cast iron with a minimum tensile strength of 30,000 PSI. All moving parts in contact with water shall be of high quality bronze or stainless steel. Pumps utilizing castings made of lower tensile strength cast iron are not acceptable.

The pump body shall be horizontally split, on a single plane, in two (2) sections, for easy removal of entire impeller assembly including wear rings and bearings from beneath the pump without disturbing piping or the mounting of the pump on the chassis.

The pump shaft shall be rigidly supported by three (3) bearings for minimum deflection. The bearings shall be heavy-duty, deep groove style bearings in the gearbox and they shall be splash lubricated.

The pump impeller shall be of hard, fine grain bronze with a mixed flow design; accurately machined, hand ground, and individually balanced. The vanes of the impeller intake eyes shall be hand ground and polished to a sharp edge, and shall be of sufficient size and design to provide ample reserve capacity utilizing minimum horsepower.

The pump shaft shall be fabricated of heat-treated, electric furnace, corrosion resistant stainless steel, and shall be super finished under the shaft seal. The pump shaft must be sealed with double lip oil seal to keep road dirt and water out of gearbox.

02-96-0505

GEAR BOX

The gear box shall be completely manufactured and tested at the pump manufacturer's factory.

The pump gearbox shall be of sufficient size to withstand up to 16,000 lbs. ft. of torque of the engine in both road and pump operating conditions. The gearbox shall be designed of ample capacity for lubrication reserve and to maintain the proper operating temperature.

The gearbox drive shafts shall be of heat-treated chrome nickel steel and shall be a minimum of 2.75 inches in diameter, on both the input and the output drives shafts. The gearbox shall withstand the full torque of the engine in both road and pump operating conditions.

All gears, both drive and pump, shall be of highest quality electric furnace chrome nickel steel. Bores shall be ground to size and the gear teeth shall be crown shaven, and hardened for smooth, quiet running, and a higher load carrying capability. An accurately cut spur design shall be provided to eliminate all possible end thrust.

The pump gear ratio shall be selected by the apparatus manufacturer to give the maximum performance with the engine and transmission selected.

02-96-0513

NFPA 2016 INTERLOCK MODULE

An interlock module shall be provided on the pump shift to comply with NFPA shift safety

10251-0002

08/20/18

Toyne Inc.

requirements.

02-96-0700

GEARCASE COOLING LINE

A cooling line shall be provided in the pump gear case. A line shall be routed from the discharge side of the pump to the gear case, through the gear case then back into the intake side of the pump.

02-96-8100

MECHANICAL SEAL

The pump shaft shall be equipped with a single mechanical type seal on the suction (inboard) side of the pump. The mechanical seal shall be a minimum of two inches in diameter and shall be spring loaded, maintenance free and self-adjusting. The mechanical seal shall be constructed of a carbon sealing ring, stainless steel coil spring, Viton rubber cup, and a tungsten carbide seat with Teflon backup seal.

02-97-4000

SACRIFICIAL PUMP ANODES

To aid in protecting the pump from internal corrosion, three sacrificial anodes shall be provided and located one in the lower section of each side inlet and one on the discharge side of the pump.

04-03-0815

FRC PUMP BOSS PRESSURE GOVERNOR SYSTEM

Fire Research Pump Boss pressure governor and monitoring display kit shall be installed. The kit shall include a control module, pressure sensor, and cables.

The following continuous displays shall be provided:

- Check engine/stop engine warning lights
- Engine rpm shown with four daylight bright LED digits more than 1/2" high
- Engine oil pressure; shown on an LED bar graph display in 10 psi increments
- Engine temperature shown on an LED bar graph display in 10 degree increments
- Battery voltage shown on an LED bar graph display in 0.5 volt increments
- PSI / RPM setting; shown on a dot matrix message display
- PSI and RPM mode LEDs
- Throttle ready LED.

A dot-matrix message display shall show diagnostic and warning messages as they occur. It shall show monitored apparatus information, stored data, and program options when selected by the operator.

The program shall store the accumulated operating hours for the pump and engine, previous incident hours, and current incident hours in a non-volatile memory. Stored elapsed hours shall be displayed at the push of a button. It shall monitor inputs and support audible and visual warning alarms for the

Toyne Inc.

following conditions:

- High Engine RPM
- Pump Overheat
- High Transmission Temperature
- Low Battery Voltage (Engine Off)
- Low Battery Voltage (Engine Running)
- High Battery Voltage
- Low Engine Oil Pressure
- High Engine Coolant Temperature

The governor shall operate in two control modes, pressure and RPM. No discharge pressure or engine RPM variation shall occur when switching between modes. A control knob that uses optical technology shall adjust pressure or RPM settings. It shall be 2" in diameter with no mechanical stops, a serrated grip, and have a red idle push button in the center.

A throttle ready LED shall light when the interlock signal is recognized. The governor shall start in pressure mode and set the engine RPM to idle. In pressure mode the governor shall automatically regulate the discharge pressure at the level set by the operator. In RPM mode the governor shall maintain the engine RPM at the level set by the operator except in the event of a discharge pressure increase. The governor shall limit a discharge pressure increase in RPM mode to a maximum of 30 psi. Other safety features shall include recognition of no water conditions with an automatic programmed response and a push button to return the engine to idle.

04-07-0329

TFT A-18 INTAKE RELIEF VALVE

A TFT model A-18 intake relief/dump valve shall be provided on the intake side of the pump to relieve excess incoming pressure. The system shall be designed to automatically restore to a non-relieving position when excessive pressure is no longer present. The pressure adjustment range shall be from 50 psi to 200 psi. The relief system shall be adjustable with a common type box end wrench.

04-07-1000

The intake relief valve shall be pre-set to 125 psi.

04-12-0400

PUMP SHIFT MECHANISM -AIR/ELECTRIC

The pump shall be shifted from road to pump by means of a cab mounted air over electric pump shift switch. The switch shall have a built in positive locking mechanism to prevent accidental movement of the switch. The locking mechanism shall require the operator to manually lift up on the switch lever to disengage the lock.

The switch shall have three positions:

- Position 1 = road position
- Position 2 = neutral position
- Position 3 = pump position

Toyne Inc.

A green indicator light shall be provided in the driving compartment and shall be energized when the pump shift has been completed. This light shall be labeled "PUMP ENGAGED".

When the apparatus is equipped with an automatic transmission, a green indicator light shall be provided in the driver's compartment. It shall be energized when both the pump shift has been completed and the chassis transmission is in pump gear. This light shall be labeled "OK TO PUMP".

04-12-5500

TRIDENT PRIMING SYSTEM

A Trident air priming system shall be provided.

04-12-8300

MANIFOLD DRAIN VALVE

The pump shall have a manifold type drain valve assembly consisting of a stainless steel plunger in a bronze body with multiple ports. The control for the valve shall be on the left side along the bottom of the panel and above the side running board. The valve shall be a rotary type with a large easy to grip handle. The valve shall be labeled "PUMP DRAIN".

04-12-9300

ICI "LEVER LIFT" BLEEDER/DRAIN VALVES

ICI 3/4" quarter turn ball type bleeder/drain valve shall be provided for each discharge and auxiliary intake. A hose shall be connected to the valve that will direct water below the apparatus and away from the immediate pump operator's location.

The control handle shall be "lever lift" style for easy actuation. The handle for the control shall have a recessed area for the color coded identification label.

04-12-9350

LOW POINT AUTO-DRAINS

Automatic drains shall be provided in low points of any discharge piping. The drain shall drain to the ground below its location. This drain shall be a supplementary drain and will not be considered the required 3/4" bleeder drain.

04-91-0300

6" LEFT (DRIVER) SIDE MASTER INTAKE

A 6" master intake shall be provided on the left (driver) side of the apparatus. The intake shall have a 6" male NST connection. The intake shall have a removable screen to prevent the entry of large objects into the pump. The screen shall be constructed of a material that will provide cathodic protection to the pump. A label shall be provided above the intake that states "DRIVER SIDE MASTER INTAKE". The label shall be color coded burgundy.

04-95-0300

LEFT SIDE MASTER INTAKE CAP

10251-0002

Toyne Inc.

A 6" FNST LH chrome cap shall be provided on the left side master intake.

05-02-0300

6" RIGHT (PASSENGER) SIDE MASTER INTAKE

A 6" master intake shall be provided on the right (passenger) side of the apparatus. The intake shall have a 6" male NST connection. The intake shall have a removable screen to prevent the entry of large objects into the pump. The screen shall be constructed of a material that will provide cathodic protection to the pump. A label shall be provided above the intake that states "PASSENGER SIDE MASTER INTAKE". The label shall be color coded burgundy.

05-07-7800

RIGHT SIDE MASTER INTAKE CAP

A 6" FNST LH chrome cap shall be provided on the right side master intake.

05-08-0100

FRONT BUMPER INTAKE

A front bumper intake shall be provided and located on the right side of the front bumper.

05-08-1600

HALE MIV-E MASTER INTAKE VALVE FOR FRONT INTAKE

The front intake shall be equipped with a Hale model MIV-E electrically operated intake valve. The valve shall be a full flow butterfly type valve designed to mount on the fire pump between the suction tube extension and the suction tube behind the pump panel. The valve shall not interfere with other suction or discharge openings on the fire pump or with the operating control properly mounted.

The entire valve shall be cast, manufactured, and tested at the pump manufacturer's factory. The valve body and related components that are in contact with water shall be fine grained corrosion resistant bronze. The butterfly disc shall be manufactured of 80,000 psi minimum yield strength heat treated cast steel then coated with a durable nitrile rubber to provide a positive seal when the valve is closed. The valve shall be hydrostatically tested to 600 psig and vacuum tested to 26" hg.

A pressure relief valve shall be provided that is factory set at 125 psi and field adjustable from 75 to 250 psi. The pressure relief valve shall provide overpressure protection for the soft suction hose even when the intake valve is closed.

The inlet valve shall be operated by a 12 VDC electric motor with the control on the pump panel. The valve shall be provided with panel placards indicating control operation. The placards shall have status lights to indicate whether the valve is open, closed, or traversing from one position to the other. The valve shall have a gear operator that will open/close the valve in no less than 3 seconds. The gear actuators shall be sealed to provide reliable service in the hard pump compartment environment. The ratio of the actuator will be such that the handwheel will close the valve in no more than 10 complete turns.

Toyne Inc.

A label stating the following will be provided near the intake: "WARNING-SERIOUS INJURY OR DEATH COULD OCCUR IF INLET IS SUPPLIED BY A PRESSURIZED SOURCE WHEN THE VALVE IS CLOSED.

05-08-1700

MANUAL MIV "BACKUP" CONTROL - FRONT INTAKE

A manually operated "backup" handwheel control shall be provided for the front intake valve and located in an accessible location. Because the backup control moves when the electric control is activated, the backup control shall not be located in any location that firefighting personnel may come into contact with the control during normal operations.

05-08-2000

FRONT MIV VALVE DRAIN

A 3/4" drain shall be provided on the valve body to allow draining of the outer side of the valve.

05-08-2400

FRONT MIV BLEEDER VALVE

A 1/4" bleeder valve shall be provided on valve body to bleed off air on the outer side of the valve.

05-09-9600

FRONT INTAKE SWIVEL CONNECTION

A **chrome plated** front suction swivel elbow with 6" MNST thread shall be provided. The elbow shall have a vertical lock to prevent vacuum leaks due to side loads and shall have dual o-rings for a positive seal. The elbow, as well as the swivel bearings, shall be brass for increased durability. A built in strainer shall also be included with the elbow.

05-11-7800

FRONT MASTER INTAKE CAP

A 6" female NST long handle chrome cap shall be provided on the front master intake.

05-60-1910

3/8" PUMP COOLING/BYPASS LINE

A 3/8" pump cooling/bypass line shall be provided from the pump discharge manifold directly into the tank.

This discharge shall implement an all brass ball type 1/4 turn valve with chrome plated handle control located on the pump panel.

The valve control handle shall indicate the open/closed position of the valve. The handle shall have a recessed area for mounting of the identification label which shall clearly state "PUMP COOLER".

Toyne Inc.

05-87-0100

TANK REFILL/RECIRCULATION DISCHARGE

A discharge shall be provided from the pump discharge manifold to allow pump cooling when necessary as well as to refill the booster tank.

The water tank fill gauge shall be directly in line with this discharge control.

05-87-0214

The valve and piping shall be 2".

05-87-0400

The refill/recirculation discharge shall be manually controlled on the pump panel.

06-02-0500

STAINLESS STEEL PIPING

All piping for discharges shall be stainless steel using stainless steel fittings. High pressure helix wire reinforced flexible piping with a minimum burst pressure of 1200 psi may be used in some areas to minimize friction losses. All flexible piping couplings shall be high tensile strength stainless steel.

All piping shall be properly supported and braced to prevent movement of piping other than what is allowed by the flexible couplings to compensate for apparatus flexing.

Any discharge manifolds provided on the apparatus must be fabricated of a minimum of schedule 10 304 marine grade piping. Use of any welded light gauge (less than Schedule 10) manifolding or plumbing will not be acceptable.

06-02-0525

The stainless steel piping shall be warranted to be free from corrosion perforation for a period of 10 years following the delivery of the apparatus.

06-02-0600

VICTAULIC COUPLINGS

Victaulic style couplings shall be used in the assembly of the pump piping system. The couplings shall allow flex in the piping and provide for a disassembly point for maintenance and repairs.

06-02-2000

VENTED LUG CAPS AND PLUGS

All intake and discharge plugs and caps and plugs shall be vented lug type designed to relieve trapped pressure and help reduce possible operator injuries.

06-03-8021

AKRON HD-8800 SERIES VALVES

All discharge and small diameter auxiliary intakes shall have heavy duty Akron 8800 series brass ball valves with stainless steel ball. This shall include the tank to pump and tank fill valve.

Toyne Inc.

06-04-0901

LEFT SIDE FORWARD AUXILIARY INTAKE

An auxiliary intake shall be provided on the left side of the pump compartment in the forward position.

06-04-0985

The intake valve and piping shall be 2 1/2".

06-04-1000

The valve shall be manually controlled from the pump operator's position.

06-04-1060

The intake shall have a 2 1/2" chrome plated female NST swivel connection with screen and a male NST chrome plated intake plug and chain.

06-04-1075

A 3/4" bleeder/drain valve shall be provided.

06-47-1815

FUTURE FOAM CAPABILITIES

The apparatus shall be pre-piped for future installation of a foam system. The manifold shall be stainless steel. This manifold shall be fed from the main pump discharge manifold and shall have a spacer pipe installed between the two manifolds with Victaulic couplings on each end. The spacer pipe shall be the length required for future installation of an electronic foam system.

To minimize the future costs of installing foam on the apparatus, there shall be no exception to this requirement.

07-00-5020

RIGHT SIDE DISCHARGES

One 2 1/2" discharge and one 4" discharge shall be provided on the right side pump panel. The 4" discharge shall be located forward of the intake and the 2 1/2" shall be located rear of the intake.

07-01-6220

One (1) right side 2 1/2" discharge(s):

07-01-6250

The right side 2 1/2" discharge shall be manually controlled on the pump panel.

07-01-7301

The discharge shall be equipped with a chrome plated brass or bright finish stainless steel discharge elbow with 2 1/2" MNST thread.

07-01-7325

A 2 1/2" chrome plated NST cap and chain shall be provided.

10251-0002

Toyne Inc.

07-05-0060

One (1) right side 4" discharge(s):

07-05-0149

The right side 4" discharge shall be manually controlled from the pump operator's position with a gear actuated hand wheel control featuring position indication.

07-05-8101

The discharge shall extend straight out of the apparatus with no elbow.

07-06-1001

A 4" chrome plated NST discharge cap shall be provided.

07-08-5091

LEFT SIDE DISCHARGE

One 2 1/2" discharge shall be provided on the left side pump panel. The discharge shall be located forward of the intake.

07-10-9591

One (1) left side 2 1/2" discharge(s):

07-11-4321

The left side 2 1/2" discharge shall be manually controlled on the pump panel with a pull/push control and gauge located adjacent to the discharge.

07-11-6100

The discharge shall be equipped with a chrome plated brass or bright finish stainless steel discharge elbow with MNST thread.

07-11-6125

A 2 1/2" chrome plated NST cap and chain shall be provided.

07-21-5000

RIGHT REAR 2 1/2" DISCHARGE

One (1) 2 1/2" discharge shall be provided on the right rear of the apparatus.

07-21-5020

The valve shall be manually controlled on the pump panel.

07-21-5340

A chrome discharge elbow shall be provided with 2 1/2" NST threads.

07-21-5351

The discharge shall be used as a pre-connected line and shall not require any cap or chain.

Toyne Inc.

07-21-5415

The right rear (passenger) 2 1/2" discharge shall be pre-piped for future foam system installation.

07-52-5529

1 3/4" CROSSLAY PRECONNECTS

Two 1 3/4" preconnected crosslays shall be provided and located above the side mount pump panel.

The crosslay compartment shall be constructed of 5052 smooth aluminum sheet material with a random brushed finish applied after fabrication. Each crosslay shall be piped using 2" piping or high pressure hose incorporating a 2" ball valve with the control on the side mount pump operator's panel.

07-52-9100

The #1 - hand line crosslay shall have the capacity to hold 200 feet of 1 3/4" or 2" fire hose and nozzle.

07-52-9106

The #2 - hand line crosslay shall have the capacity to hold 200 feet of 1 3/4" or 2" fire hose and nozzle.

07-54-4510

The valve(s) shall be manually controlled on the pump panel.

07-55-0000

There shall be two (2) 2" swivel elbows with 1 1/2" male NST hose thread connections provided on the cross lay hose beds. The swivels shall be mounted in a position to prevent hose "pinching" at the hose thread connection.

07-55-1106

3/4" manual drain valves shall be provided for all 1 3/4" crosslays. The valves shall have an all brass body with heavy duty neoprene seal.

07-55-1305

The #1 hand line crosslay shall be pre-piped for future foam system installation.

07-55-1326

The #2 hand line crosslay shall be pre-piped for future foam system installation.

07-56-4125

2 1/2" CROSSLAY PRECONNECT(S)

One (1) 2 1/2" pre-connected crosslay(s) shall be provided and located above the side mount pump panel.

The crosslay compartment shall be constructed of 5052 smooth aluminum sheet material with a random brushed finish applied after fabrication. Each crosslay shall be piped using 2 1/2" piping or high pressure hose incorporating a 2 1/2" ball valve with the control on the side mount pump operator's panel.

10251-0002

Toyne Inc.

07-56-4601

The #1 - 2 1/2" crosslay shall have the capacity to hold 200 feet of 2 1/2" or 3" fire hose and nozzle.

07-56-5010

The valve(s) shall be manually controlled on the pump panel.

07-56-5320

There shall be one (1) 2 1/2" swivel elbow with a 2 1/2" male NST hose thread connection provided on the 2 1/2" cross lay hose bed. The swivel shall be mounted in a position to prevent hose "pinching" at the hose thread connection.

07-56-5406

The #1 2 1/2" crosslay shall be pre-piped for future foam system installation.

07-56-9100

3/4" manual drain valves shall be provided for all 2 1/2" crosslays. The valves shall have an all brass body with heavy duty neoprene seal.

07-59-1100

CROSSLAY COMPARTMENT ENDS - BLACK WEBBING

The crosslay compartment shall be enclosed on each end using a heavy duty webbing to prevent hose from accidentally unloading. The webbing shall be black.

A yellow nozzle strap shall be provided for each crosslay. The strap shall be designed to loop through the nozzle handle and secured to the apparatus to keep nozzle from coming out of the crosslay compartment without manually disconnecting the nozzle strap.

07-59-1200

HINGED ALUMINUM TREADBRITE CROSSLAY COVER

An aluminum treadbrite hinged cover shall be provided to cover the crosslay compartment. The cover shall have a full length polished stainless steel hinge. A chrome plated lift handle shall be provided on each end of the cover. Rubber protection blocks shall be provided in any area where the cover may come into contact with a painted surface.

07-59-5051

3" MONITOR DISCHARGE

A 3" monitor discharge shall be provided above the pump compartment. The discharge piping shall extend above the pump compartment a sufficient distance to allow use of the deck gun.

07-60-0760

The valve shall be manually controlled on the pump panel. The control shall have an integrated slow closing mechanism to comply with NFPA 1901.

10251-0002

08/20/18

Toyne Inc.

08-01-0000

1 3/4" FRONT BUMPER DISCHARGE(S)

There shall be one (1) 1 3/4" discharge(s) provided on the front of the apparatus. Piping and valve shall be 2".

08-01-0180

The valve shall be manually controlled on the pump panel.

08-01-0330

The front bumper 1 3/4" discharge shall be pre-piped for future foam system installation.

08-01-1200

The front bumper discharge shall have a 1 1/2" MNST thread connection.

08-05-8200

FRONT DISCHARGE HOSE CONNECTION - CHROME SWIVEL

The hose connection for the discharge shall be located immediately adjacent to the hosewell. A **chrome plated or polished stainless steel** swivel shall be provided. The lid for the hosewell shall be notched to allow for the hose to be preconnected.

08-05-8450

FRONT BUMPER DISCHARGE HOSE CONNECTION - DRIVER'S SIDE

The hose connection for the front bumper discharge shall be on the driver's side.

09-18-2925

PUMP COMPARTMENT

A modular pump compartment with side mounted pump operator's panel shall be provided. The modular design of the pump compartment shall allow the compartment to be fully independent of the apparatus body. A 1" flex joint shall be provided between the pump compartment and the apparatus body.

The modular design of the pump compartment shall allow the entire pump system, including the pump itself, to be removed from the apparatus in a one-piece assembly while leaving the body intact and without having to cut any sheet metal or welds.

09-18-3000

STAINLESS STEEL PUMP COMPARTMENT CONSTRUCTION

The entire pump compartment shall be constructed using only 304 marine grade stainless steel fabricated sheeting with a #4 annealed and polished finish on all exterior surfaces. The pump compartment shall not require any finish painting. Due to the extreme twisting and flexing that all fire apparatus are subjected to, aluminum shall not be used in any portion of the pump compartment structural support. The use of any type of enclosed tubing that requires the use of self-tapping or any other type of machine screw shall not be acceptable.

10251-0002

Toyne Inc.

09-21-4000

PUMP COMPARTMENT RUNNING BOARDS

The pump compartment side running boards shall be constructed of NFPA compliant slip resistant aluminum treadbrite.

10-90-0200

PUMP COMPARTMENT ACCESS DOOR - FRONT WALL

An easily removable aluminum treadbrite pump access door shall be provided in the front of the pump compartment. This panel shall be held in place with a stainless steel D ring handle which operates two pin latches on the interior of the door, one on each end. The D ring handle shall be single directional and must be manually turned to latch/unlatch the latch assembly.

10-90-2100

PUMP COMPARTMENT RIGHT SIDE ACCESS DOOR - SIDE MOUNT

A brushed stainless steel hinged access door shall be provided on the right side of the pump compartment. The doors shall have pneumatic hold open devices and push button type flush latches.

10-93-2000

SIDE MOUNT BRUSHED STAINLESS STEEL PUMP PANEL

All controls and instruments shall be located on the left side of the apparatus. All discharge and intake valve controls shall be located on the left side pump panel.

BRUSHED STAINLESS STEEL PUMP PANELS

The left and right side pump panels shall be constructed of 304 2B marine grade brushed stainless steel with a #4 brushed and polished finish. The panels shall be held into place with two latches on the top to allow for easy removal of the panels.

The upper section of the left side pump panel shall be constructed of the same 304 2B marine grade stainless steel. The upper section shall be vertically hinged and have a chrome plated latch to secure the panel when closed.

10-96-0300

LED SIDE MOUNT PUMP PANEL LIGHTS

The side mount pump panel shall be illuminated using a track type LED light assembly.

The light shall be constructed of an unbreakable type clear poly flexible material housed in an aluminum extrusion mounted behind a brushed stainless steel light shield provided across the top of the gauge panel.

10251-0002

Toyne Inc.

10-96-0350

LED RIGHT SIDE DISCHARGE/INTAKE PANEL LIGHTS

The right side discharge and intake panels shall be illuminated using a track type LED light assembly.

The light shall be constructed of an unbreakable type clear poly type flexible material housed in an aluminum extrusion mounted behind a brushed stainless steel light shield provided across the top of the hinged access door.

10-96-0869

AUTOMATIC PUMP PANEL LIGHT ACTIVATION

The pump panel lights above the pump control panel shall function automatically with the pump shift activation.

10-96-1990

PUSH/PULL VALVE CONTROL HANDLES

The apparatus pump panel shall be equipped with Innovative Controls side mount valve controls to open/close the manually operated discharge valves.

The ergonomically designed ¼ turn push-pull T-handle shall be chrome plated zinc with recessed labels for color coding and verbiage. The control rod shall provide a true positive lock to eliminate valve drift. Bronze and Teflon impregnated stainless steel bushings in both ends of rod housing shall minimize rod deflection, never need lubrication, and ensure consistent long term operation.

The control assembly shall include a decorative chrome plated zinc panel mounting bezel.

10-96-2040

DISCHARGE VALVE CONTROL HANDLE LAYOUT

All discharge valve control handles shall be located in one or two horizontal lines across the mid-section of the pump panel. The control handles shall be located immediately below their corresponding pressure gauge for ease of pump operation.

Any pump operator's panel discharge(s) shall have direct horizontal lever style control(s) with the gauge adjacent to the control.

10-96-3151

VALVE CONTROL LINKAGES

All manual valve controls requiring remote actuation shall have control rod linkages constructed of 1/2" galvanized pipe and shall implement heavy ball swivel joints and clevises for smooth valve operation.

11-00-8801

10251-0002

Toyne Inc.

ICI MASTER PUMP DISCHARGE PRESSURE GAUGE

An ICI 4" diameter master pressure gauge shall be provided to indicate the main pump discharge pressure. The gauge shall read from 30" hg vacuum to 400 psi and shall be accurate within +/- 1%. The gauge shall be glycerin filled (-40F to +150F) and have a high impact resistant clear acrylic lens.

11-00-8865

ICI MASTER PUMP INTAKE PRESSURE GAUGE

An ICI 4" diameter master pressure gauge shall be provided to indicate the pump intake pressure. The gauge shall read from 30" hg vacuum to 400 psi and shall be accurate within +/- 1%. The gauge shall be glycerin filled (-40F to +150F), read up to 400 psi, be accurate within +/- 1% and have a high impact resistant clear acrylic lens.

11-01-1845

The master intake and discharge gauges shall have bright finish stainless steel bezels.

11-01-1900

The master gauge dials shall be white with black markings. The needle shall match the color of the markings.

11-01-2000

The master intake gauge shall be clearly labeled "PUMP INTAKE" and shall be located to the left of the master discharge pressure gauge. The label shall be burgundy color.

The master discharge gauge shall be clearly labeled "PUMP DISCHARGE" and shall be located to the right of the intake pressure gauge. The label shall be black color.

11-01-2005

The master intake/discharge pressure gauges shall have a lifetime non-yellowing and freeze warranty. The gauges shall also be warranted for 4 years for defects in materials and workmanship, including fluid leakage. The warranty will not cover labor costs and/or transportation costs.

11-09-3500

PRESSURE/VACUUM TEST PLUGS

Underwriter's test plug adapters shall be provided for connection of pump test gauges.

11-13-6100

INNOVATIVE CONTROLS SL PLUS TANK GAUGE - PUMP PANEL

An Innovative Controls model SL Plus tank gauge shall be provided on the pump panel. The gauge shall feature a 180 degree highly visible wide view ultra-bright LED display showing the level of the booster tank.

11-14-8000

TANK GAUGE PARK BRAKE DISABLE

10251-0002

Toyne Inc.

The tank gauge(s) shall be disabled when the park brake is released so that the lights are not a distraction when the vehicle is in motion.

11-78-A190

ICI DISCHARGE PRESSURE GAUGES

Unless otherwise specified, each 1 1/2" or larger discharge shall have an ICI pressure gauge. The gauge shall be glycerin filled (-40F to +150F), read from 0 - 400 psi, be accurate within +/- 1% and have a high impact resistant clear acrylic lens.

11-78-A396

The individual discharge pressure gauges shall have a 2 3/4" diameter.

11-78-A415

The discharge pressure gauge dials shall be white with black markings. The needle shall match the color of the markings.

11-78-A450

The pressure gauge shall be directly in line with or adjacent to the discharge control handle for the discharge that they provide pressure readout for. **For ease of operation, this requirement must be strictly adhered to. There shall be no exception to this requirement.**

11-78-A455

The gauges shall be clearly labeled with permanent color coded labels.

11-78-A470

The discharge pressure gauges shall have a lifetime non-yellowing and freeze warranty. The gauge shall also be warranted for four years for defects in materials and workmanship including fluid leakage. Warranty will not cover labor costs and/or transportation costs.

11-80-2500

IDENTIFICATION LABELS FOR PUMP PANEL

Innovative Controls verbiage label bezels shall be installed. The bezel assemblies will be used to identify apparatus components. These labels shall be designed and manufactured to withstand the specified apparatus service environment.

Where required, the verbiage label bezel assemblies shall include a chrome plated panel mount bezel with durable easy to read UV resistant polycarbonate inserts featuring the specified verbiage and color coding. The UV resistant polycarbonate verbiage and color inserts shall be sub-surface screen printed to eliminate the possibility of wear and protect the inks from fading. Both the insert labels and bezel shall be backed with 3M permanent adhesive (200MP), which meets UL969 and NFPA standards.

The color scheme for the discharge and intake labels shall be per NFPA A.16.9.1.

13-00-1400

BOOSTER TANK- UNITED PLASTIC FABRICATING, INC.

The tank shall have a LIFETIME warranty provided by United Plastic Fabricating, Inc.

10251-0002

Toyne Inc.

The tank exterior shell shall be constructed of minimum 1/2" thick PT3 polypropylene sheet stock. This material shall be non-corrosive stress relieved thermoplastic which is U.V. stabilized for maximum protection. The booster tank shall be of a specific configuration and is designed to be completely independent of the body and compartments. All joints and seams shall be nitrogen welded and tested for maximum strength and integrity. The tank construction shall include Poly Pro Seal technology. A sealant shall be installed between the plastic components prior to being fusion welded. This sealing method will provide a liquid barrier offering leak protection in the event of a weld compromise.

The transverse swash partitions shall be manufactured of 3/8" PT3 polypropylene material. The longitudinal swash partitions shall be constructed of 3/8" PT3 polypropylene and extend through the cover to allow for positive welding and maximum integrity. All partitions shall be equipped with vent and air holes to permit movement of air and water between compartments. The partitions shall be designed to provide maximum water flow. All swash partitions shall interlock with one another and are welded to each other as well as to the walls of the tank. All partition spacing shall be compliant with NFPA 1091 recommendations.

The top of the booster tank shall be fitted with removable lifting eyes.

The tank cradle assembly shall be designed to provide support to the tank. The assembly shall be approved by the manufacturer of the tank.

13-01-1000

SPECIAL TANK DESIGN

The booster tank shall be "L" shaped to allow for a lower hosebed height. The front section of the tank shall be higher than the rear section bringing the overall hosebed height down to a more accessible height.

There shall be **no exception** to this requirement.

14-00-2800

BOOSTER TANK CAPACITY 750 GALLONS

The poly booster tank shall have a capacity of 750 U.S. gallons.

14-08-2301

BOOSTER TANK FILL TOWER - LEFT SIDE FRONT

The tank shall have a combination vent and manual fill tower. The fill tower shall be constructed of 1/2" polypropylene and shall be a minimum of **10" x 10"** outer dimension. The tower shall be located in the left front corner of the hose bed. The tower shall have a 1/4" thick removable polypropylene screen and polypropylene hinged type cover.

14-08-2500

4" TANK OVERFLOW

A 4" diameter tank vent/overflow shall be provided and integrated into the tank. The piping shall be a minimum of schedule 40 polypropylene designed to run through the tank and discharge behind the

10251-0002

Toyne Inc.

rear wheels.

14-08-4021

1" TANK SUMP DRAIN

A 1" drain shall be provided in the bottom of the tank sump to fully drain the tank. The drain shall use 1" stainless steel piping with a 1" valve. The control for the valve shall be removed to the driver's side of the apparatus just under and behind the side rub rail. The drain control handle shall be labeled "TANK DRAIN".

14-08-4030

3" TANK SUMP CLEAN OUT PLUG

A 3" tank sump clean out plug shall be provided in the bottom of the tank sump.

14-10-0110

25 GALLON CLASS A FOAM TANK

A 25 gallon Class A foam tank shall be provided. The tank shall have all connections necessary to connect to the foam system and shall also have a 1/4 turn drain valve with hose attached to allow the tank to be drained.

The tank shall have an **8" x 8"** fill tower with hinged type lid with latch. A vent shall be provided in the lid.

A label shall be provided on the lid that reads "CLASS A FOAM TANK FILL" and "WARNING: DO NOT MIX BRANDS OR TYPES OF FOAM".

14-10-1400

CLASS A FOAM TANK/BOOSTER TANK INTEGRATION

The class A foam tank shall be integrated into the apparatus booster tank. The foam tank shall not be separate from the booster tank.

16-20-0010

3" TANK TO PUMP

One 3" tank to pump line(s) and valve(s) shall be provided between the tank and the pump. The piping from the sump to the valve shall be 4".

16-29-1000

The tank to pump valve shall be manually controlled on the pump panel.

16-29-1090

TANK TO PUMP CHECK VALVE

A check valve assembly shall be provided on the pump. The valve shall prevent unintentional back

10251-0002

Toyne Inc.

filling of the tank through the tank to pump line. Connection from the valve to the tank shall be made by using a non-collapsible flexible rubber hose.

28-00-0215

HOT DIPPED GALVANIZED SUB FRAME

The tank cradle and body substructure shall be constructed of high strength ASTM A-36 structural steel with 36,000 psi minimum yield strength. The entire substructure shall be framed and jig welded together to insure a truly square assembly. The substructure shall be fastened to the chassis rails so that it may be easily removed from the chassis for repair, replacement or mounting to a new chassis.

After complete assembly of the tank cradle substructure, the entire assembly shall be hot dipped galvanized for superior corrosion protection.

Due to the extreme duty that this apparatus will experience during its intended service life and to prevent rusting and corrosion from shortening the service life of this apparatus, sub frames fabricated of painted/undercoated steel or aluminum tubing shall not be acceptable.

28-00-0501

20 YEAR SUB-STRUCTURE WARRANTY

The tank cradle and body substructure shall have a 20 warranty covering failure due to corrosion perforation or structural design error.

This warranty shall be in effect for 20 years after delivery of the apparatus to the customer. **NO EXCEPTION.**

28-00-1000

HYPER-FLEX BODY MOUNTING

The body module assembly shall be mounted to the chassis frame rails with "*Hyper-Flex*" vibration and shock isolators using a forward mounting system. Flexible neoprene pads, or U-springs especially developed for the expected weight and torsional flexing of the apparatus body, shall be incorporated into the system to eliminate chassis frame rail flex from transmitting harmful loads and twisting onto the body.

28-02-5000

100" BODY WIDTH

The apparatus body shall be 100" wide from side to side measuring from the rub rail mounting surface.

28-04-0400

APPARATUS BODY MATERIAL

The entire apparatus body shall be constructed of 304 marine grade stainless steel with a #4 annealed and polished finish. The interior of the apparatus body shall not require any finish painting. The compartment interiors must be a #4 finish. Mill finish or DA sanded finish will not be acceptable.

Toyne Inc.

28-04-1000

APPARATUS BODY CONSTRUCTION

The entire apparatus body shall be formed by sheering and bending the sheet metal. Metal tubular structures or extrusions shall not be used in the construction of the apparatus body. All edges of the sheared metal shall be sanded to remove any sharp sheering edges prior to bending the metal. After sheering and bending, the body shall be assembled on a jig table that is designed to hold all parts securely in place to insure an accurately built apparatus body.

28-04-1200

APPARATUS BODY ASSEMBLY METHOD

The entire apparatus body shall be assembled using only bolted type construction. All apparatus body parts shall be able to be unbolted without the need to cut welds, etc. No exceptions to this requirement as all apparatus manufacturers have the capability to manufacture apparatus bodies in this manner.

28-04-1500

COMPARTMENT FLOORS

All compartment floors shall be constructed of 304 marine grade stainless steel with a # 4 annealed and polished finish on the interior surface. The drain ports shall be designed to prevent road spray from entering the compartment. The front edge shall consist of a minimum of two bends to provide additional strength in the compartment floor and shall then form the lower door jamb.

All compartment floors shall be sweep out design. This shall include the lower side compartments, any compartments above the wheel well, any transverse compartments, and the rear face compartment(s).

Any exception to this requirement will cause immediate rejection of bid.

28-04-1510

COMPARTMENT WEIGHT RATING

Each compartment shall be designed to carry 1,000 lbs. of equipment distributed throughout the compartment.

28-04-2000

INTERIOR COMPARTMENT SURFACES

All visible interior compartment surfaces shall be 304 marine grade stainless steel with a # 4 annealed and polished finish. Surfaces that are painted or coated in any manner, raw material or any surface with any type sanded finish are not acceptable.

28-04-2500

FRONT COMPARTMENT CORNERS

The apparatus body front compartment corners and vertical faces on both sides shall be constructed

Toyne Inc.

of 304 marine grade stainless steel with a # 4 annealed and polished finish. The corners shall be a one-piece fabrication from top to bottom and from the inner body panel to the outer face of the compartment to provide maximum strength. Corners using structural support channels or extrusions that require two or more pieces shall not be implemented.

The # 4 finish corner shall wrap around the side of the apparatus body and form the front compartment door jamb providing front corner protection.

28-04-3600

REAR COMPARTMENT CORNERS - BRUSHED

The apparatus body rear compartment corners and vertical faces on both sides shall be constructed of 304 marine grade stainless steel with a # 4 annealed and polished finish. The corners shall be a one-piece fabrication from top to bottom and from the inner body panel to the outer face of the compartment to provide maximum strength. Corners using structural support channels or extrusions that require two or more pieces shall not be implemented.

The # 4 finish corner shall wrap around the side of the apparatus body and form the rear compartment door jamb providing front corner protection.

28-04-4500

COMPARTMENT TOPS/CEILINGS

The apparatus body compartment tops shall be constructed of 304 marine grade stainless steel with a # 4 annealed and polished finish on the interior surface.

28-04-4700

COMPARTMENT TOP OVERLAY

The compartment top shall be overlaid with 1/8 aluminum treadbrite. The aluminum treadbrite shall be an overlay only and shall not form any structural part of the apparatus body or shall the bottom side of the treadbrite be visible when looking into the compartment.

28-04-5500

PAINTED FENDERWELLS

The left and right side rear fender wells shall be constructed of stainless sheet steel. The fender wells shall be radius cut and shall have a full circular inner liner to prevent rust pockets and for ease of cleaning. A 1" gap shall be provided on the bottom of each side of the circular liner to allow drainage of water and for easy cleanout. Sufficient clearance shall be provided for tire chains. Before the booster tank is installed, the fender wells shall be thoroughly cleaned and all seams sealed to prevent corrosion in the fender well area.

28-04-5503

PAINTED FENDERWELLS

The fender wells shall be finish painted the primary exterior color of the apparatus.

28-04-5660

10251-0002

Toyne Inc.

UPPER DOOR POSTS - PAINTED

The upper door post to the front and rear of the compartment door above the rear wheels shall be constructed of ultra-smooth 304 marine grade stainless sheet steel with a minimum tensile strength of 90,000 psi.

The outer surface of these door posts shall be finished painted.

28-04-6011

REMOVABLE INNER FENDER LINER

The fender wells shall be radius cut and shall have a circular inner liner to prevent corrosion pockets and for ease of cleaning. The inner liner shall be constructed of high impact polypropylene material and shall be fully removable for chassis suspension access.

28-04-6013

To prevent the accumulation of potential corrosive materials in the fender well area, there shall be no exception to the removable inner fender liner.

28-04-6025

STAINLESS STEEL FENDERETTE

The fender wells shall be trimmed with a polished stainless steel fenderette. The stainless steel fenderette shall be secured into place with stainless steel fasteners and shall be easily removable for replacement. A black rubber fender welting shall be provided between the fenderette and the inner liner surface. The fenderettes shall protrude from the apparatus body a maximum of 1".

28-04-6028

REPLACEABLE FENDERETTE

The stainless steel fenderette shall be secured to the apparatus body with stainless steel fasteners and shall be easily removable for replacement.

Fenderettes that are welded to the apparatus body are not acceptable.

28-04-6600

OUTER BODY SIDES

The outer left and right side body panels above the compartment tops shall be constructed of 304 2B marine grade stainless steel with a # 4 brushed finish and shall not require any finish paint.

28-12-2100

COMPARTMENT VENTILATION

Each compartment shall have a removable metal ventilation plate to allow for air movement in the compartment. A cleanable filter material shall be provided behind the plate.

Plastic cover plates will not be acceptable.

Toyne Inc.

28-21-5000

ROM SERIES IV ROLL UP COMPARTMENT DOORS

For all compartments requiring roll up doors, Robinson (ROM) Series IV roll up doors shall be installed.

Each shutter slat, track, bottom rail, and drip rail shall be constructed from anodized 6063 T6 aluminum.

The shutter slats shall feature a double wall extrusion 0.315" thick with a concave interior surface to minimize loose equipment jamming the shutter door closed. Shutter slats shall feature an interlocking end shoe to prevent side to side binding of the shutter door during operation. Slat must have interlocking joints with an inverted locking flange. The slat inner seal shall be a one piece PVC extrusion designed to prevent metal to metal contact while minimizing dirt and water from entering the compartment.

The shutter door tracks shall be one piece design with integral overlapping flange to provide a clean finished look without the need of caulk. Door tracks shall feature an extruded Santoprene rubber double lip low profile side seal with a silicone co-extruded back to reduce friction during shutter operation.

The shutter bottom rail shall be a one piece double wall extrusion with integrated finger pull. The finger pull shall be curved upward with a linear striated surface to improve operator grip while operating the shutter door. The bottom rail shall have a smooth contoured interior surface to prevent loose equipment from jamming the shutter door. Bottom rail seal shall be made from Santoprene and shall be a double "V" seal to prevent water and debris from entering compartment. The bottom rail lift bar shall be a one piece "D" shaped aluminum extrusion with linear striations to improve operator grip during operation. The lift bar shall have a wall thickness of 0.125" and be supported by no less than two pivot blocks constructed from Type 66 Glass filled reinforced nylon for superior strength. The bottom rail end blocks shall have incorporated drain holes which will allow any moisture that collects inside the extrusion to drain out.

Shutter door shall have an enclosed counter balance system. The system shall be 4" in diameter and held in place by 2 heavy duty 18 gauge zinc plated plates. The counter balance system shall have 2 over-molded rubber guide wheels to provide a smooth transition from vertical track to counter balance system; no foam material of any kind shall be permitted or used in this area.

28-90-1100

STAINLESS STEEL COATED FASTENERS

All fasteners used in the finish construction of the apparatus body shall be marine grade stainless steel. Fasteners that pass through a dissimilar metal panel shall be Magna-Gard, or equal, coated to help prevent metal reaction and corrosion.

As the Magna-Gard, or equal, coating is a "baked on" type coating providing for excellent adhesion to the fastener, spray on type coatings may be used in conjunction with the Magna-Gard, or equal, but not in place of it.

Because dissimilar metal corrosion is a common occurrence on all apparatus and the Magna-Gard (or similar "baked on" coatings) fasteners are commercially available to all manufacturers and is not a proprietary product, there shall be no exception to this requirement.

Toyne Inc.

42-55-0001

SINGLE AXLE CHASSIS

43-04-1800

DRIVER'S SIDE COMPARTMENT IN FRONT OF THE REAR WHEELS

A compartment shall be provided in front of the rear wheels. The compartment interior dimensions shall be 67" high x 35.75" wide with the lower 28" of the compartment being 26" usable depth and the remaining upper section being 14" usable depth.

The compartment shall have a roll up door with a satin finish.

43-06-1100

DRIVER'S SIDE ABOVE WHEEL COMPARTMENT

A compartment shall be provided above the rear wheels. The compartment interior dimensions shall be 37" high x 63.75" wide x 14" usable depth.

The compartment shall have roll up door with a satin finish.

43-13-0835

DRIVER'S SIDE COMPARTMENT BEHIND REAR WHEELS

A compartment shall be provided behind the rear wheels. The compartment interior dimensions shall be 67" high x 32" wide x 26" useable depth in a portion of the lower section and the remaining upper section being 14" usable depth.

The compartment shall have a roll up door with a satin finish.

43-34-0500

PASSENGER'S SIDE COMPARTMENT IN FRONT OF THE REAR WHEELS

A compartment shall be provided in front of the rear wheels. The compartment interior dimensions shall be 36.5" high x 35.75" wide with the lower 28" of the compartment being 26" usable depth and the remaining upper section being 14" usable depth.

The compartment shall have a roll up door with a satin finish.

43-39-8835

PASSENGER'S SIDE COMPARTMENT BEHIND THE REAR WHEELS

A low compartment shall be provided behind the rear wheels. The compartment interior dimensions shall be 36.5" high x 32" wide x 26" useable depth in a portion of the lower section and the remaining upper section being 14" usable depth.

The compartment shall have a roll up door with a satin finish.

Toyne Inc.

49-01-0390

REAR FACE COMPARTMENT

A rear compartment shall be provided on the apparatus just ahead of the rear step. The compartment shall be a minimum of 26" useable depth.

49-01-0470

REAR COMPARTMENT HEIGHT

The rear facing compartment shall extend upward and shall be flush with the top of the booster tank to maximize the height of the rear compartment.

There shall not be a void area between the top of the rear facing compartment and the bottom of the hose bed nor shall the booster tank extend over the rear compartment.

49-01-0540

REAR FACE COMPARTMENT DOOR - ROLL UP

The rear compartment shall have a roll up door. The door shall have a satin finish.

49-01-0600

DRIVER'S SIDE REAR COMPARTMENT - TRANSVERSE

The driver's side compartment behind the rear wheels shall be open into the rear facing compartment (transverse).

49-01-0620

PASSENGER'S SIDE REAR COMPARTMENT - TRANSVERSE

The passenger's side compartment behind the rear wheels shall open into the rear facing compartment (transverse).

49-66-2615

UPPER DOOR JAMB EXTENSIONS - HARD SUCTION COMPARTMENTS

The upper door jamb of the side compartments shall be extended upward on both sides for storage of hard suction hose, one each side.

49-66-2621

HARD SUCTION ACCESS DOORS

An aluminum tread plate vertically hinged door with a slam-type latch shall be provided for each hard suction compartment. The latch shall be activated by a large "D" ring control. The use of lift-and-turn or small snap type latches on this door shall not be acceptable.

49-66-2638

10251-0002

Toyne Inc.

UPPER DOOR JAMB EXTENSIONS FINISH PAINTED

The outer surface of the upper door jamb shall be finish painted to match the exterior of the apparatus body color.

49-90-0200

REAR STEP MATERIAL - NFPA ALUMINUM TREADBRITE

The rear step shall be constructed of NFPA complaint bright finish aluminum treadbrite.

49-90-0417

16" REAR TAILBOARD STEP

A 16" depth rear tailboard step shall be provided on the apparatus. The step shall be spaced from the rear face of the apparatus body a minimum of 3/4" for easy wash out.

49-99-5600

RUBRAILS - BRIGHT ANODIZED ALUMINUM

Extruded aluminum rub rails shall be provided on the apparatus body sides. The rub rails shall have a bright finish with anodized coating to protect the finish. The rub rails shall be spaced from the apparatus body a minimum of 1/4" with poly spacers.

The rub rails must be bolted on to the apparatus body to allow easy replacement if damaged. Rub rails that are permanently fastened to the apparatus body by welding or any other permanent method will not be acceptable. **NO EXCEPTION WILL BE ALLOWED TO THIS REQUIREMENT.**

49-99-5625

RUB RAIL ENDS

The rub rail ends shall be 'capped' with a high impact resistant black EPDM contoured block.

50-00-0200

HOSE BED FLOORING

The floor of the hose bed shall be constructed of fiber reinforced Dura-Dek, or equal, material.

The top portion of each "T" cross section shall measure 1 5/8" wide x 3/16" thick with beaded ends. The vertical portion shall be 3/16" thick tapering out at the bottom to a thickness of 1/2" and have an overall height of 1". The "T" sections shall be spaced 3/4" apart to allow for drainage and ventilation.

The flooring shall then be protected with a polyurethane coating to screen out ultraviolet rays. The gray colored coating shall be baked on and include a slip resistant material.

50-00-2000

HOSE BED - 68" WIDE

The hose bed shall be 68" wide from side to side.

Toyne Inc.

50-00-7000

HOSE BED CAPACITY

The hose bed shall have the capacity to carry the following hose load:

50-03-1300

HOSE BED DIVIDER(S)

There shall be one (1) hose bed divider(s) to partition off hose. The divider(s) shall be constructed of 3/16" thick aluminum plate material. The lower edge of the divider(s) shall have a two inch 90-degree bend toward one side and a 2" x 2" x 3/16" aluminum angle welded to the other side.

The divider(s) shall be adjustable by sliding in tracks which are recessed flush into the hose bed flooring, one on front and one on rear. The divider shall be held in place by two bolts on each end.

The upper rear corner of the divider(s) shall have a minimum of a 3" radius cut with a 1" aluminum rub plate.

50-03-1600

HOSE BED DIVIDER UPPER SUPPORT

An upper horizontal support shall be provided at the rear of the hosebed to help prevent hosebed divider deflection. The support shall have an integrated adjustment track to allow divider adjustment.

50-03-5010

HOSE BED BULKHEAD

A bulkhead divider shall be provided in the front area of the hose bed separating the hose bed from the tank fill tower(s). The balance of this area that is not occupied by fill tower or other mounted equipment shall be used as a dunnage compartment.

50-03-5930

HOSE BED COVER WITH VELCRO FASTENERS

A heavy duty vinyl coated nylon hose bed cover shall be provided to protect the hose load from the weather. The cover shall extend from the front of the hose bed to the rear and then extend downward to cover the exposed rear of the bed.

The cover shall have a double reinforced area where the cover comes into contact with the upper rear corners of the hose bed dividers. The cover shall be secured to the apparatus using Velcro on the sides and lift dots on front.

The rear of the cover shall be secured to the apparatus using positive mechanical latches.

50-03-6110

HOSE BED COVER - RED

10251-0002

Toyne Inc.

The hose bed cover shall be red.

50-10-1700

LOW MOUNT ENCLOSED LADDER COMPARTMENT

A ladder storage compartment shall be provided on the right side of the apparatus with an access door on the rear. The compartment shall be located below the hose bed level and shall not be located above or through the booster tank. The compartment shall be located between the booster tank and the right side compartments.

For ease of removal and replacement with limited staffing, the compartment shall be designed to carry all portable ladders vertically on their beams. Ladder racks that carry the ladders horizontally shall not be acceptable.

The compartment shall be constructed of 5052 1/8" aluminum with a brushed finish. Individual slides fabricated of 5052 H32 alloy aluminum shall be provided in the compartment on both sides to allow individual storage for all ladders. The slides shall be provided with permanently attached Rodex poly slip blocks with tapered front and rear edges allow easier loading/unloading of the ladders.

All ladders shall be capable of being removed individually without disturbing the remaining ladders.

50-10-2504

LADDER COMPARTMENT DOOR

A smooth aluminum vertically hinged door with a slam-type latch shall be provided on the compartment. The latch shall be activated by a large "D" ring control. The use of lift-and-turn or small snap type latches on this door shall not be acceptable.

The door shall be covered with Chevron material.

50-10-2550

PIKE POLE STORAGE

Storage for two straight handle pike poles shall be provided in the ladder storage compartment.

50-10-3700

LADDER COMPARTMENT LIGHT

An LED light shall be provided in the ladder storage compartment. The light shall be mounted just inside the ladder compartment access door and activated with an automatic door switch.

The light switch shall be incorporated into the door ajar warning system in the cab.

50-11-0800

DUO SAFETY 24' 2-SECTION ALUMINUM LADDER

Toyne Inc.

One (1) Duo Safety 900A 24' NFPA compliant two section aluminum extension ladder provided and mounted.

50-11-1100

DUO SAFETY 14' ALUMINUM ROOF LADDER

One (1) Duo Safety model 775A 14' NFPA compliant aluminum roof ladder with folding hooks shall be provided and mounted.

50-11-1400

DUO SAFETY 10' ALUMINUM FOLDING ATTIC LADDER

One (1) Duo Safety 585A 10' NFPA compliant aluminum folding attic ladder shall be provided and mounted.

50-20-9290

6" x 10' HARD SUCTION HOSES (2)

Two sections of 6" diameter x 10' length clear lightweight PVC hard suction hose shall be provided.

50-21-0749

The hard suction shall be coupled long handle female NST x rocker lug male NST.

NOTE: The long handles on the FNST end shall be folding type.

50-21-0800

The hard suction shall be Kocheck brand.

51-05-0100

COMPARTMENT SHELF TRACKS - ALUMINUM

Four (4) sets consisting of two heavy duty aluminum adjustable tracks shall be provided in specified compartments, one for each end of shelf.

The tracks shall not be welded to the apparatus body.

51-06-0100

SHALLOW DEPTH COMPARTMENT SHELVING

There shall be four (4) shallow depth shelves provided. The shelves shall be constructed of 1/8" smooth aluminum with a 2" upward bend on the front and rear edges.

51-06-0120

The shelves shall have a random orbit sanded finish.

51-06-7600

10251-0002

Toyne Inc.

TURTLE TILE SHELF MAT

Each shallow depth shelf shall have Turtle Tile matting.

52-01-9000

COMPARTMENT SCBA TRACKS - HORIZONTAL

Two (2) sets consisting of two heavy duty horizontally mounted adjustable tracks shall be provided and mounted to the rear walls of the specified compartment(s).

The tracks shall not be welded to the apparatus body.

52-02-1305

DRIVER'S SIDE FRONT OF WHEELWELL SPARE CYLINDER COMPARTMENT

A compartment shall be provided in the wheel area in front of the rear axle on the driver's side to hold a total of two (2) spare SCBA cylinders.

The compartment shall be injection molded high strength polyethylene designed specifically for the SCBA cylinder storage. The compartment shall be slanted towards the rear and have a drain port at the low point of the compartment.

52-02-1365

DRIVER'S SIDE REAR OF WHEELWELL SPARE CYLINDER COMPARTMENT

A compartment shall be provided in the wheel area behind the rear axle on the driver's side to hold a total of two (2) spare SCBA cylinders.

The compartment shall be injection molded high strength polyethylene designed specifically for the SCBA cylinder storage. The compartment shall be slanted towards the rear and have a drain port at the low point of the compartment.

52-02-1405

PASSENGER'S SIDE FRONT OF WHEELWELL SPARE CYLINDER COMPARTMENT

A compartment shall be provided in the wheel area in front of the rear axle on the passenger's side to hold a total of two (2) spare SCBA cylinders.

The compartment shall be injection molded high strength polyethylene designed specifically for the SCBA cylinder storage. The compartment shall be slanted towards the rear and have a drain port at the low point of the compartment.

52-02-1455

PASSENGER'S SIDE REAR OF WHEELWELL SPARE CYLINDER COMPARTMENT

A compartment shall be provided in the wheel area behind the rear axle on the passenger's side to hold a total of two (2) spare SCBA cylinders.

Toyne Inc.

The compartment shall be injection molded high strength polyethylene designed specifically for the SCBA cylinder storage. The compartment shall be slanted towards the rear and have a drain port at the low point of the compartment.

52-02-1550

WHEELWELL STORAGE COMPARTMENT DOORS – BRUSHED FINISH STAINLESS

Brushed finish stainless steel access doors shall be provided on each wheel well storage compartment in the wheel well.

52-02-2100

WHEELWELL SCBA CYLINDER COMPARTMENT RETENTION STRAPS

One 1" wide loop of high visibility yellow webbing shall be installed in each wheel well spare cylinder compartment for each cylinder to be stored in the compartment. The loop(s) shall be designed to loop around the cylinder valve and help prevent the cylinder from sliding out of the compartment if the door is not latched or fails.

52-15-0150

TURTLE TILE FLOOR MATS

All lower level apparatus body compartment floors shall be provided with 3/4" thick Turtle Tile modular 12" x 12" square tiles with perforated surface for ventilation and air circulation. The tiles shall be easily removable for cleaning the compartment. The tiles shall interlock into each other to form a "one piece" floor liner.

Floors with permanent mounted or bolted in place accessories will not have floor mats.

52-15-0176

TURTLE TILE - BLACK

The Turtle Tile shall be black in color.

55-50-1050

FOLDING ACCESS STEPS

Austin FS-200 CHR chrome plated folding access steps shall be provided in areas listed in these specifications. All access steps provided on the apparatus shall support a minimum static load of 500 lbs. and be mounted in accordance to recommended mounting procedures as outlined by NFPA 1901. The steps shall be **minimum** of 6.5" wide x 6.5" depth. The steps shall be attached to the apparatus using stainless steel bolts with locking type nuts.

55-50-1201

Four NFPA compliant folding steps shall be provided on the right side front compartment face.

55-50-1301

Four NFPA compliant folding steps shall be provided on the left side front compartment face.

10251-0002

Toyne Inc.

55-50-1500

Three NFPA compliant folding steps shall be provided on the rear of the apparatus on the left side.

56-00-0050

NFPA KNURLED FINISH HANDRAILS

All handrails shall be 1 1/4" diameter extruded aluminum "knurled finish" with chrome plated stanchions. Rubber gaskets shall be provided between the stanchions and any painted surfaces.

56-00-0205

LEFT REAR VERTICAL HAND RAILS

An NFPA compliant handrail shall be provided on the left rear of the apparatus for boarding the rear step and using the left rear hose bed access steps.

56-00-0206

RIGHT REAR VERTICAL HAND RAILS

An NFPA compliant handrail shall be provided on the right rear of the apparatus for boarding the rear step and using the right rear hose bed access steps.

56-00-0550

RIGHT FRONT GRAB RAIL

A 12" NFPA compliant horizontal handrail shall be provided on the right front of the apparatus towards the front of the hose bed.

56-00-0600

LEFT FRONT GRAB RAIL

A 12" NFPA compliant horizontal handrail shall be provided on the left front of the apparatus towards the front of the hose bed.

56-00-0650

LEFT REAR GRAB RAIL

A 12" NFPA compliant horizontal handrail shall be provided on the left rear of the apparatus towards the rear of the hose bed.

56-00-1000

INTERMEDIATE REAR HORIZONTAL HAND RAIL

An intermediate horizontal handrail shall be provided on the rear of the apparatus.

59-10-1001

10251-0002

Toyne Inc.

NFPA 1901 CERTIFIED 12 VOLT ELECTRICAL SYSTEM

The 12-volt apparatus body electrical system shall be provided and shall be in compliance with NFPA 1901 testing and certification procedures as follows:

59-10-6050

NFPA MINIMUM ELECTRICAL LOAD DEFINITION

The NFPA 1901 defined minimum electrical load shall consist of the total amperage required to simultaneously operate the following in a stationary mode:

- Propulsion engine and transmission.
- The clearance and marker lights.
- Communication equipment (5 amp default).
- Illumination of all walking surfaces, the ground at all egress points, control and instrumentation panels and 50% of total compartment lighting.
- Minimum warning lights required for "blocking right of way" mode.
- The current to simultaneously operate and fire pump and all specified electrical devices.
- Anything defined by the purchaser, in the advertised specifications, to be critical to the mission of the apparatus.

59-10-6100

RESERVE CAPACITY TEST

The first electrical test to be performed will be the Reserve Capacity Test. All items listed in NFPA Minimum Load Definition shall be activated with the engine shut off. After 10 minutes of operation, those items shall be deactivated. After deactivation, the battery system shall have ample reserve to start the engine.

59-10-6120

ALTERNATOR PERFORMANCE TEST AT IDLE

An "alternator performance test at idle" test shall be completed. The minimum continuous electrical load shall be activated with the engine running at idle speed. When the engine temperature has been stabilized at idle speed, the battery system shall be tested to detect any battery discharge current.

59-10-6130

ALTERNATOR PERFORMANCE TEST AT FULL LOAD

An "alternator performance test at full load" test shall be completed. The minimum continuous electrical load shall be activated with the engine running up to the engine manufacturer's governed speed for a 2 hour period.

59-10-6140

TEST CONDITIONS

All electrical testing shall be performed with the engine compartment at approximately 200 degrees.

59-10-6300

10251-0002

Toyne Inc.

12-VOLT WIRING SYSTEM

All 12-volt electrical wiring shall be SXL cross link rated to carry 125% of the maximum current for which the circuit is protected. The wire shall be of sufficient size so that voltage drop in any electrical device does not exceed 10%. All wiring shall be color, number, and function coded with the number and function being printed every 3" along the entire length of all apparatus body wires (as required by NFPA 1901). All wiring shall be routed through heavy duty PVC split loom securely attached and protected against heat, oil, and physical damage. All locations where the wire passes through a body panel shall be protected with electrical grommets.

All connections shall be made using mechanical connectors and be screwed to terminal or junction box with machine screws. Wire nut, insulation displacement, or piercing connections shall not be used.

All circuits shall be provided with properly rated low voltage over current protective devices of the automatic reset type.

Removable access panels shall be provided to provide access to the wire and electrical components.

59-11-0100

MULTI-PLEXED ELECTRICAL SYSTEM

The apparatus body electrical system shall incorporate a Multiplexed Electrical System. The multiplex system shall consist of all solid-state components contained inside aluminum extrusions referred to as nodes. Each node shall consist of (24) output channels and (24) input channels. All inputs and outputs will be configured into an electrical harness utilizing Deutsch connectors. The nodes must be waterproof and not require special mounting requirements.

The system, at a minimum, shall be capable of performing the following functions: load management sequencing, switch loads, receive digital and analog signals, perform and report diagnostics, continuously report vehicle status and the system is expandable.

Placement of nodes throughout the apparatus enables a reduction in wire harness bundles, elimination of redundant harnesses and separate circuit boards, relay and circuit breakers, electrical hardware, separate electrical or interlock subsystems and associated electronics for controlling various electrical loads and inputs. The multiplex system shall be field re-programmable and re-configurable by any authorized dealer or service center. This complete system shall eliminate the need for the following separate components or devices: load manager, load sequencer, warning lamp flasher, door open notification system, interlock modules, separate volt meter and ammeter.

The Base System Shall Include:

- Total Load Management
- Load Shedding Capabilities
- Load Sequencing Capabilities
- "On-Board" Diagnostics Readout
- Very Reliable, Solid-State Hardware
- Error Reporting
- Continuous system monitoring and reporting

Toyne Inc.

- Emergency warning lamp flasher
- Door Ajar System
- Field Configurable
- Expandability Capabilities
- Advanced PC Diagnostics

As-built wiring harness drawings and a master circuit list of electrical circuits that the apparatus builder installs shall be furnished in the delivery manuals. These schematics must show the electrical system broken down into separate functions, or small groups of related functions. Schematics shall depict circuit numbers, electrical components, harnesses, and connectors from beginning to end. **A single drawing for all electrical circuits installed by the apparatus builder shall not be accepted.**

59-11-1210

VMUX WARRANTY

The VMUX multiplexed electrical system shall be warranted, under normal use and service, for a period of four years. One year parts and labor and the remaining three years parts only.

59-11-4000

AUTOMATIC HIGH IDLE FUNCTION

An automatic high idle system shall be installed and will activate whenever the system voltage drops below a determined voltage. The high idle will remain on until adequate voltage is achieved.

59-21-0101

REAR LICENSE PLATE LIGHT/BRACKET

A chrome plated LED license plate light shall be provided on the rear of the apparatus.

A license plate mounting bracket shall be provided that spaces the license plate away from the apparatus body.

59-22-1000

CLEARANCE LIGHTS/REFLECTORS

All apparatus body clearance lights shall be LED style. All lower clearance lights and reflectors shall be mounted in a manner that provides protection from damage, and shall comply with FMVSS-108 regulations.

59-22-3000

MID-MOUNTED SIDE TURN SIGNAL - LED

An amber LED side turn signal shall be provided in the mid-section area of the apparatus on both sides.

59-23-0110

LED PUMP COMPARTMENT LIGHTS (2)

10251-0002

Toyne Inc.

Two LED compartment lights shall be provided to illuminate the pump compartment. The lights shall function with the pump operators gauge panel lights.

60-01-1426

DUAL TRACK TYPE LED COMPARTMENT LIGHTING

Each apparatus body compartment shall have two track type LED lights vertically mounted in the compartment. The lights shall be constructed of an unbreakable type clear poly type flexible material housed in an aluminum extrusion.

A compartment that is considered a 'full height' compartment shall each have two 48" long light sections and a 'low height' or above wheel compartment shall each have two 18" long sections.

The lights shall function automatically and independently of other compartments when the compartment door is opened. **Compartment lighting systems that are controlled by a single, dash mounted switch are not acceptable.**

60-01-1600

COMPARTMENT LIGHT SWITCHES

Each hinged apparatus body door compartment shall have a magnetic style reed indicator switch.

Each roll up door shall have an integral door open indicator magnet in the lift bar. If the bar is not properly closed, it shall activate the "Door Open" light in the cab.

The compartment lights shall function automatically when the door is opened. A master compartment light switch shall not be acceptable.

60-01-5210

LED PERIMETER GROUND LIGHTING -three (3)

There shall be three (3) LED perimeter ground lights furnished and installed on the apparatus body. The lights shall have an unbreakable polycarbonate lens and housing. The lights shall be sealed to help prevent moisture entry.

The ground lights shall be activated with the parking brake.

NOTE: Chassis ground lighting is listed in the chassis section of this specification.

60-01-8285

LED APPARATUS BODY STEP LIGHTING

All apparatus steps and running boards shall be illuminated using chrome plated or stainless steel LED lights. The lights shall function automatically with the park brake.

60-01-8290

GROUND/STEP LIGHTING CUTOFF SWITCH

10251-0002

Toyne Inc.

A ground/step light cut off switch shall be provided in the cab to allow the driver to disable the ground lights and other lights that activate when the parking brake is set. The switch shall automatically re-set itself when the parking brake is released.

60-10-2008

WHELEN M6 QUAD-CLUSTER TAILLIGHTS - LED

Whelen M6BTT 4" x 6" LED taillights and M6T 4" x 6" LED turn signals shall be provided. The backup lights shall be M6BUW 4" x 6" clear LED's.

An additional space shall be provided in the quad-cluster for the lower C warning lights.

M6FCV4 polished trim housings shall be provided.

60-10-3501

BACKUP LIGHTS PARK FUNCTION

The backup lights shall automatically activate when the park brake is set to provide work lighting at the rear of the apparatus.

65-15-6990

ZONE A UPPER WARNING LIGHTING

The lightbar shall be provided on the chassis. Specifications for the lightbar are listed in the chassis specifications.

65-75-4504

SIDE FACING LOWER REAR WARNING LIGHTS

One Whelen model M6RC red LED light with clear lens shall be provided shall be provided on each side of the apparatus as low and as far rearward as possible on the apparatus. A chrome bezel shall be provided around the lights.

65-81-3304

REAR FACING LOWER WARNING LIGHTS

Two Whelen model M6RC red LED lights with clear lens shall be provided on the lower rear of the apparatus. A chrome bezel shall be provided around the lights.

66-02-1127

WHELEN M9RC UPPER ZONE B/D WARNING LIGHTING

Two Whelen model M9RC red LED light heads with clear lens shall be mounted on each side of the apparatus above the side compartments. An M9FC chrome bezel shall be provided for each light.

Toyne Inc.

66-11-1110

WHELEN M9RC UPPER ZONE C WARNING LIGHTING

Two Whelen model M9RC red LED light heads with clear lens shall be mounted on the rear of the apparatus, one each side. An M9FC chrome bezel shall be provided for each light.

67-01-1230

WHELEN TAL65 TRAFFIC ADVISOR

A Whelen TAL65 36" 6 lamp LED directional traffic advisor shall be provided and mounted on the rear of the apparatus. The advisor shall be subject to load management shedding to comply with NFPA 1901.

67-01-2215

DIRECTIONAL LIGHT MOUNTING

The directional light shall be surface mounted to the rear face of the apparatus.

74-02-3935

WHELEN M9LZC LED SCENE LIGHTS

Six Whelen M9LZC 9" x 7" LED scene lights shall be provided and mounted two on each side and two on the rear. The lights shall have a chrome plate trim bezel.

74-09-5000

12 VOLT SCENE LIGHT ACTIVATION SWITCH (1)

A single switch shall be located on the cab control console to activate the 12 volt scene light(s).

74-20-0400

DUAL FUNCTION REAR SCENE LIGHT(S)

The rear facing scene light(s) shall activate automatically when the apparatus transmission is placed into reverse.

74-45-0700

LED HOSE BED LIGHT

One LED light shall be provided and mounted in the front of the hose bed .

The light shall be controlled by the pump panel light switch.

75-08-7100

FRC SPECTRA LED TELESCOPING LIGHT - 12 VOLT

10251-0002

Toyne Inc.

One (1) Fire Research model SPA530-Q20 bottom raising telescoping light(s) shall be mounted on the apparatus. The lighthouse shall be 12 volt LED and shall draw a maximum of 18 amps creating 20,000 lumens.

The telescoping pole shall be constructed of heavy wall anodized tube. The pole shall be secured in any raised position with a non-directional advanced twist lock locking device. The twist lock mechanism shall have a knurled positive grip. The light(s) shall include a three wire coiled cord extended from the pole bottom.

The light(s) shall be electrically tested so that they are safe for their intended use. The light(s) shall be certified by Underwriters Laboratories (UL) and shall meet/exceed NFPA 1901.

75-08-7126

The pole(s) shall be equipped with a FRC "NS" no scratch kit to help prevent contact with the pole mounting surface.

75-08-7136

The telescoping light(s) shall be equipped with an on/off switch on the pump panel.

75-08-7192

The telescoping light(s) shall be mounted on the exterior rear wall of the cab.

90-02-3209

FIRE HELMET MOUNTING

The end user of the apparatus shall be responsible for insuring that all helmets are either stored in an exterior compartment or a securely mounted to NFPA 1901 standards inside the cab.

91-00-0200

PAINT PROCEDURE - PPG DELFLEET BASE COAT/CLEAR COAT

All interior compartment surfaces shall remain # brushed stainless steel. There shall be no paint or any other type of coating on the interior compartment surfaces. Standard mill finish, DA finish or swirled finish shall not be accepted.

Any exterior surfaces that are to be painted shall be individually listed in the apparatus body portion of this specification.

All seams or flanges on the apparatus body shall be caulked or properly sealed to prevent moisture accumulation in flanged areas.

91-00-0701

PPG CERTIFIED 10 YEAR LIMITED PAINT WARRANTY

The apparatus body exterior finish paint shall have a 10 year limited warranty. The warranty shall be certified by the manufacturer of the paint. Documentation of this shall be provided to the end user.

Toyne Inc.

Any warranty that is extended by the apparatus manufacturer and not backed by the paint manufacturer will not be acceptable.

PPG Commercial OEM Product Warranty Coverage:

Warranty Inclusions:

- Delamination of the topcoat and/or other layers of paint.
- Cracking or checking due to failure of the product.
- Excessive loss of gloss caused by cracking, checking and hazing.

Warranty Exclusions:

- Paint deterioration caused by blisters, bubbles, flaking or other degradation due to rust or corrosion originating from the substrate.
- Hazing, chalking or loss of gloss caused by improper care, abrasive polishes, cleaning agents, heavy-duty pressure washing, or aggressive mechanical wash systems.
- Paint deterioration caused by abuse, scratches, chips, gloss reduction, accidents, acid rain, chemical fallout, road treatment materials/chemicals or acts of nature.
- Any paint that was not applied by Toyne, Inc.
- Claims presented without proper Warranty documentation.
- Failure on finishes performed by Non-PPG Commercial Certified Technicians.
- Failure on finishes due to inadequate film builds.
- Failures due to improper cleaning or surface preparation or failure to follow the product use instructions.

THESE ARE THE ONLY WARRANTIES THAT PPG MAKES, AND ALL OTHER EXPRESSED OR IMPLIED WARRANTIES, INCLUDING WITHOUT LIMITATIONS, ANY WARRANTY OF FITNESS FOR PARTICULAR PURPOSE OR USE, ARE DISCLAIMED BY PPG.

91-00-0800

ELECTROLYSIS CORROSION CONTROL

The apparatus shall be assembled using ECK or electrolysis corrosion control, on all high corrosion potential areas, such as door latches, door hinges, trim plates, fenderettes, etc. This coating is a high zinc compound that shall act as a sacrificial barrier to help minimize electrolysis and corrosion between dissimilar metals. This shall be in addition to any other barrier material that may be used.

91-00-1099

SINGLE COLOR APPARATUS BODY PAINT

The apparatus body shall have a single color scheme.

91-00-4100

APPARATUS BODY UNDERCOATING

10251-0002

Toyne Inc.

The apparatus body shall be undercoated after assembly is completed. A bituminous based automotive type undercoat shall be used. Care shall be taken to avoid undercoat application to items that would hinder normal maintenance.

91-00-9000

COMPARTMENT INTERIORS - BRUSHED STAINLESS FINISH

The compartment interiors shall be brushed stainless steel # 4 finish. The brushed finish shall be as provided by the manufacturer of the material.

Interiors with any type of paint, sprayed-on coatings, DA finish, or standard "mill finish" will not be acceptable.

91-02-2100

LETTERING

The apparatus dealer shall provide and apply all vehicle lettering and numbering.

91-04-1000

1"-6"-1" NFPA REFLECTIVE STRIPE

A 6" reflective stripe shall be applied to the apparatus.

A 1" gap shall be provided on both the top and bottom of the 6" stripe followed by a 1" reflective stripe above and below the upper and lower gap.

A single 6" stripe shall be applied to the front if space does not permit for the 3 stripe pattern.

The striping shall be applied to a minimum of 50% of the length of the apparatus on each side and 25% across the front of the apparatus. The stripe shall comply with NFPA 1901 requirements.

91-04-1705

PRIMARY REFLECTIVE STRIPE COLOR - WHITE

The primary reflective stripe shall be 680-10 white.

91-04-1735

SECONDARY UPPER REFLECTIVE STRIPE COLOR - WHITE

The secondary upper reflective stripe shall be 680-10 white.

91-04-1765

SECONDARY LOWER REFLECTIVE STRIPE COLOR - WHITE

The secondary lower reflective stripe shall be 680-10 white.

10251-0002

Toyne Inc.

91-05-0100

REFLECTIVE STRIPE - HORIZONTAL

The reflective stripe shall be applied in a straight horizontal line from front to rear. The height of the stripe on the chassis cab and the body shall be as close as possible.

91-11-1622

REAR CHEVRON STRIPING

A minimum of 50 percent of the rear vertical surface of the apparatus shall be covered with 6 inch alternating red and fluorescent yellow green retro-reflective striping. The striping shall slope downward away from the centerline of the apparatus at a 45-degree angle.

The retro-reflective material shall conform to the requirements of ASTM D 4956 "Standard Specification for Retro-Reflective Sheeting for Traffic Control", Type I or better.

94-72-2550

FUEL TANK ACCESS

A removable panel shall be provided on the rear of the apparatus for maintenance access to the top of the fuel tank.

94-75-4600

ENGINE HORIZONTAL EXHAUST

Shielding shall be provided between the apparatus body and the exhaust pipe if necessary to deflect heat away from the body. The exhaust system shall be designed and installed to comply with EPA equipment requirements and shall not be modified.

94-75-6985

DRIVER'S SIDE FUEL FILL

A chassis fuel fill shall be located in the driver's side rear wheel well. The fuel fill shall be properly vented.

94-75-7000

LEFT (DRIVER'S) SIDE FUEL FILL DOOR

A chassis fuel fill shall be located in the driver's side rear wheel well. The fill shall be located behind a brushed stainless steel hinged door with flush latch. The fuel fill shall be properly vented.

95-01-0075

REAR MUD FLAPS

Heavy duty black rubber mud flaps shall be provided on the rear wheels. The mud flaps shall be attached to the apparatus in the rear wheel well area using heavy duty stainless steel retention straps

10251-0002

Toyne Inc.

that are secured into place using stainless steel fasteners.

95-03-0000

REAR PULLING EYES

Two rear 3/4" CRS pulling eyes shall be provided under the rear tailboard. The eyes shall have a minimum of a 3" clear opening for passing chains through the eye.

99-70-1010

BATTERY DANGERS LABEL - FAMA01

A permanent label shall be provided near the battery location that warns of potential injury or death that could be caused by the batteries. The label shall also state precautions that should be taken while working on or around the batteries.

99-70-1020

ROTATING SHAFTS DANGER LABEL - FAMA02

A permanent label shall be provided on each side of the frame rail and in any other location(s) where rotating shaft hazards are apparent. The label shall warn of potential injury or death that could be caused by the movement of the shaft(s) as well as precautions that should be taken while working on or around them.

99-70-1030

HOT SURFACE DANGERS LABEL - FAMA03

A permanent label shall be provided near any hot surface that warns of potential injury or death that could be caused by contact with the surface. The label shall also state precautions that should be taken while working on or around the surface.

99-70-1040

HOT EXHAUST DANGERS LABEL - FAMA04

A permanent label shall be provided near any hot exhaust surface that warns of potential injury or death that could be caused by contact with the surface. The label shall also state precautions that should be taken while working on or around the surface.

99-70-1050

SPINNING ENGINE FAN DANGER LABEL - FAMA05

A permanent label shall be provided on both sides of the engine fan. The label shall warn of potential injury or death that could be caused by the movement of the fan as well as precautions that should be taken while working on or around them.

99-70-1070

SEATED AND BELTED WARNING LABEL - FAMA07

10251-0002

Toyne Inc.

A permanent label shall be provided that is visible to all occupants that states that they should be seated and belted while the apparatus is in motion. The label shall also state potential injuries or death that could be caused if the safety belts are not used properly.

99-70-1090

AIR CONDITIONING REFRIGERANT WARNING LABEL - FAMA09

If the apparatus is equipped with any type of air conditioning system, a permanent label shall be provided that is located in an area that would be visible to service personnel. The label shall state that the system contains R134A, the necessary precautions that should be taken and the dangers of working on or around the system.

99-70-1100

CAB INTERIOR EQUIPMENT MOUNTING DANGER LABEL - FAMA10

A permanent label shall be provided inside of the cab warning of the dangers of unsecured equipment inside the cab. The label shall state that all equipment shall be properly secured and also warn of potential injury or death that could be caused by failing to do so.

99-70-1110

SCBA SEAT DANGER LABEL - FAMA11

If the apparatus is equipped with SCBA seats in the cab, a permanent label shall be provided inside of the cab warning of the dangers of using the seat without the SCBA properly secured or seat insert in place. The label shall warn of potential injury or death that could be caused by improper use of the seat.

99-70-1120

FIRE SERVICE TIRE RATING LABEL - FAMA12

A permanent label shall be provided inside of the cab in view of the driver while entering the cab warning of the dangers of improper use of the tires on the apparatus. The label shall also warn of potential injury or death that could be caused by improper tire use or condition.

99-70-1130

ELECTRONIC STABILITY CONTROL LABEL - FAMA13

If the apparatus is equipped with an electronic stability control system, a permanent label shall be provided inside of the cab in view of the driver warning of the dangers of improper operation of the apparatus and the importance of safe driving. The label shall also warn of potential injury or death that could be caused by improper operation of the apparatus.

99-70-1140

MAXIMUM OCCUPANCY LABEL - FAMA14

A permanent label shall be provided inside of the cab in view of the driver stating the maximum number of personnel that can ride in the apparatus. The label shall also warn of potential injury or

Toyne Inc.

death that could be caused by exceeding the stated capacity.

99-70-1150

DO NOT WEAR HELMET LABEL - FAMA15

A permanent label shall be provided inside of the cab in view of all seated positions stating that helmets should not be worn in cab. The label shall also warn of potential injury or death that could be caused by wearing helmet in cab.

99-70-1170

VEHICLE BACKING LABEL - FAMA17

A permanent label shall be provided inside of the cab in view of the driver advising of proper procedures to following when the apparatus is in reverse motion. The label shall also warn of potential injury or death that be caused by failing to follow proper procedures.

99-70-1180

INTAKE/DISCHARGE CAP PRESSURE LABEL - FAMA18

A permanent label shall be provided in all areas that intakes and discharges are capped. The label shall give instruction on how to properly remove the cap. The label shall also warn of potential dangers, injury or death that be caused by failing to follow proper cap removal procedures.

99-70-1270

HOSE RESTRAINT LABEL - FAMA22

A permanent label shall be provided near any hose storage area. The label shall instruct the operator to insure that all hose is properly secured prior to placing the apparatus in motion and to provide warning of potential dangers, including injury or death, in failing to do so.

99-70-1300

ACCESS STEPS/LADDER LABEL - FAMA23

A permanent label shall be provided at any area of the apparatus where personnel will be boarding or exiting the apparatus. The label shall instruct the operator in the proper method of climbing into or onto the apparatus as well as exiting and provide indication of potential injury or death that could occur in failing to do so.

99-70-1340

DO NOT RIDE ON REAR STEP WARNING LABEL - FAMA24

A permanent label shall be provided at the rear step area stating that riding in this area while the vehicle is in motion is prohibited and shall warn of the potential dangers, including injury or death, in doing so.

99-70-1350

TRAINED OPERATOR ONLY LABEL - FAMA25

A permanent label shall be provided on the pump panel that states that only properly trained

Toyne Inc.

personnel should operate the apparatus and shall indicate that injury or death could occur as a result.

99-70-1370

NOT A STEP WARNING LABEL - FAMA26

A permanent label shall be provided in any horizontal location that a firefighter may feel tempted to use as a step but is not designed, constructed or intended to be a stepping, standing or walking surface. The label shall state that the surface is not intended for this purpose and indicate potential injury or death in doing so.

99-70-1371

COMPARTMENT TOP WARNING LABEL - FAMA26

A permanent label shall be provided on the front and rear of the compartment tops on both sides warning that the area is not designed, constructed or intended to be a stepping, standing or walking surface. The label shall state that the surface is not intended for this purpose and indicate potential injury or death in doing so.

99-70-1373

FRONT BUMPER EXTENSION WARNING LABEL - FAMA26

A permanent label shall be provided on the front bumper extension warning that the area is not designed, constructed or intended to be a stepping, standing or walking surface. The label shall state that the surface is not intended for this purpose and indicate potential injury or death in doing so.

99-70-1620

CAB TILT WARNING LABEL - FAMA41

A permanent label shall be provided inside the driver's door warning of potential injury or death that could be received in the area under or around a tilted cab. The label shall also state safety precautions that should be taken when the cab is tilted.

99-70-1630

SIREN NOISE WARNING LABEL - FAMA42

A permanent label shall be provided inside the driver's door warning of potential injury that could be received from the noise of the siren. The label shall also state safety precautions that should be taken when the siren is in use.

99-72-2000

FLUID CAPACITY LABEL

A permanent plate shall be mounted in the driver's compartment specifying the quantity and type of the following fluids used in the apparatus (if applicable) for normal maintenance:

- Engine oil.
- Engine coolant.
- Chassis transmission fluid.
- Pump transmission fluid.

Toyne Inc.

- Pump primer fluid.
- Drive axle fluid.
- Air conditioning refrigerant.
- Air conditioning lubrication oil.
- Power steering fluid.
- Cab-tilt mechanism fluid (if applicable).
- Transfer case fluid.
- Equipment rack fluid.
- CAFS compressor system lubricant.
- Generator system lubricant.
- Front tire cold pressure.
- Rear tire cold pressure.
- Maximum tire speed ratings.

99-72-2020

LENGTH, HEIGHT, WEIGHT LABEL

A permanent plate or label shall be provided in the cab stating the overall length, height and the gross vehicle weight rating (GVWR), in tons, of the completed apparatus.

The wording on this label shall indicate that the information on the plate/label was current at the time of manufacture and if the overall height of the apparatus changes while the vehicle is in service, the purchaser shall revise the height dimension on the plate.

99-72-6050

PUMP CERTIFICATIONS

Where applicable, the following documents shall be provided with the completed apparatus:

- Pump manufacturer's certification of suction capability.
- Special condition certifications, if any.
- Pump manufacturer's approval for stationary pumping.
- Engine manufacturer's certified brake horsepower curve showing maximum governed speed.
- Pump manufacturer's certification of hydrostatic test.
- Pump manufacturer's certification of hydrodynamic test, if required. Certification of inspection and tests for the fire pump.

99-73-0100

OPTICAL WARNING LIGHT CERTIFICATION

The emergency warning light system shall be certified using one of the available methods provided for in NFPA 1901 13.8.16.

99-73-0150

SIREN CERTIFICATION

The siren manufacturer shall certify the siren to NFPA 1901 13.9.1.1.

99-73-0250

10251-0002

Toyne Inc.

ELECTRICAL SYSTEM PERFORMANCE CERTIFICATION

A written load analysis and the results of the electrical system performance test shall be provided with the completed apparatus. The load analysis shall include the following:

- Nameplate rating of the alternator.
- The alternator rating under the conditions specified in NFPA 1901 13.3.2.
- Each of the component loads specified in NFPA 1901 13.3.3 that make up the minimum continuous electrical load.
- Additional electrical loads that, when added to the minimum continuous electrical load, determine the total continuous electrical load.
- Each individual intermittent electrical load.

99-73-0551

BOOSTER TANK CAPACITY CERTIFICATION

The manufacturer shall certify the capacity of the booster tank. Certification shall be documented on the Manufacturer's Record of Construction document.

99-73-0810

CLASS A FOAM TANK CERTIFICATION

Certification of class A foam tank capacity shall be provided.

99-73-0850

NFPA SLIP RESISTANCE CERTIFICATION

Any materials used as a stepping, standing or walking surface shall be certified to be compliant with NFPA 1901 15.7.4. Documentation shall be provided with the completed apparatus.

99-77-0100

WEIGHT CERTIFICATION

Documents from a certified scale showing actual loading on the front, rear and overall apparatus shall be provided. The apparatus shall be scaled with the water tank full but without personnel, equipment and hose.

99-77-1050

VEHICLE ROLLOVER STABILITY

The apparatus shall be certified to NFPA 1901 Rollover Stability requirements using the calculated/measured center of gravity method.

99-88-0000

UNDERWRITER'S LABORATORIES TESTING

The apparatus shall undergo an Underwriter's Laboratories Certification Test to insure that the completed apparatus meets the requirements of NFPA 1901. The certificate shall be provided to the

10251-0002

Toyne Inc.

purchaser upon completion. Underwriter's Laboratories shall also perform the required testing on the entire installed electrical system. Self-certification by the apparatus manufacturer will not be acceptable.

99-88-0510

MANUFACTURER'S RECORD OF APPARATUS CONSTRUCTION

All information required to comply with NFPA 1901 4.20.1 shall be provided with the completed apparatus.

99-88-0520

OPERATIONS AND SERVICE DOCUMENTATION

The apparatus shall be complete with all operation and service documentation covering the apparatus as delivered and accepted. The documentation shall address the inspection, service and operations of the apparatus and all major components as required in NFPA 1901 4.20.2.

99-90-0100

"AS BUILT" APPARATUS BODY OWNERS MANUALS (2)

Two "as built" apparatus body owner's manual USB drives shall be provided with the apparatus. All apparatus body electrical schematics shall be provided as well as all instructional and maintenance manuals on components provided and permanently mounted on the apparatus. A copy of the final apparatus body build specifications shall also be included on the drive. The USB shall be "read only" and shall not allow modification.

To eliminate component confusion, generic documentation with equipment that is not provided on the apparatus body shall not be acceptable.

99-90-2000

FAMA FIRE APPARATUS SAFETY GUIDE

One (1) FAMA Fire Apparatus Safety Guide(s) shall be provided with the completed apparatus.

99-98-0025

STATEMENT OF EXCEPTION - NFPA MISCELLANEOUS REQUIRED EQUIPMENT

The customer shall be responsible for providing all NFPA required miscellaneous equipment that is not contained within these specifications. All required equipment must be properly installed on the apparatus and in working condition prior to the apparatus being placed into service.

99-98-4950

FAMILIARIZATION AND DEMONSTRATION

Upon completion of the new apparatus, an authorized properly trained representative of the manufacturer shall perform a "Familiarization and Demonstration" overview of the apparatus and related components.

Toyne Inc.

The Department shall provide the representative with a written list, by full proper names, of the individual(s) that are to receive the overview. Upon completion of the overview, each person in attendance will be required to acknowledge, by signature, that they understand the operation of the apparatus and all related components.

99-98-5022

CHASSIS FAMILIARIZATION

Familiarization of the apparatus shall include the following:

- How to locate gauges or indicators and check all fluid levels and operational use of the apparatus.
- How to tilt the chassis cab or hood assembly for access to the engine, fire pump (if applicable), or aerial control (if applicable), or any other device to allow access to fluids or for required maintenance.
- Interior cab controls, instruments, mirrors, safety devices or alarms, brake operations, transmission control, pump controls (if applicable) exhaust regeneration (if applicable), seat adjustments, warning light engagement and other operational equipment.

99-98-5030

FIRE PUMP FAMILIARIZATION

Familiarization of the apparatus shall include the following items related to the fire pump system:

- Setting the parking brake, proper transmission gear and the fire pump engagement operations.
- Throttle control.
- Primer and tank-to-pump operation.
- Use of pressure control device.
- Tank refilling operations.
- Proper operation of discharge controls.
- Proper shutdown and draining of the system.

99-98-5150

POST ACCEPTANCE TRAINING REQUIREMENTS

After apparatus acceptance, the Department shall be responsible for ongoing training of personnel. The Department shall not allow untrained or undertrained personnel to operate the apparatus or any included feature of the apparatus.